

Chapter 2 Part A:

In-car engine repair procedures

Contents

Auxiliary drivebelt check and renewal	See Chapter 1	Flywheel/driveplate - removal, inspection and refitting	21
Camshaft oil seals - renewal	12	General information	1
Camshafts and hydraulic tappets - removal, inspection and refitting	13	Inlet manifold - removal and refitting	6
Compression test - description and interpretation	3	Oil cooler - removal and refitting	17
Crankshaft oil seals - renewal	20	Oil level sensor - removal and refitting	18
Crankshaft pulley - removal and refitting	8	Oil pressure warning light switch - removal and refitting	19
Cylinder head - removal and refitting	14	Oil pump - removal, inspection and refitting	16
Cylinder head and valve components - cleaning and inspection	See Chapter 2B	Repair operations possible with the engine in the vehicle	2
Cylinder head cover - removal and refitting	5	Spark plug renewal	See Chapter 1
Engine oil and filter change	See Chapter 1	Sump - removal and refitting	15
Engine oil level check	See Chapter 1	Timing belt - removal, refitting and adjustment	10
Engine overhaul - general information	See Chapter 2B	Timing belt covers - removal and refitting	9
Engine/transmission - removal and refitting	See Chapter 2B	Timing belt tensioner and toothed pulleys - removal, inspection and refitting	11
Engine/transmission mountings - inspection and renewal	22	Top Dead Centre (TDC) for No 1 piston - locating	4
Exhaust manifold - removal, inspection and refitting	7	Water pump - removal and refitting	See Chapter 3

Degrees of difficulty

Easy , suitable for novice with little experience 	Fairly easy , suitable for beginner with some experience 	Fairly difficult , suitable for competent DIY mechanic 	Difficult , suitable for experienced DIY mechanic 	Very difficult , suitable for expert DIY or professional 
--	---	---	--	---

Specifications

General

Engine type	Four-cylinder, in-line, double overhead camshafts
Engine code:	
1.6 litre models	LIF
1.8 litre models	RKA
2.0 litre models	NGA
Capacity:	
1.6 litre models	1597 cc
1.8 litre models	1796 cc
2.0 litre models	1988 cc
Bore:	
1.6 litre models	76.0 mm
1.8 litre models	80.6 mm
2.0 litre models	84.8 mm
Stroke - all models	88.0 mm
Compression ratio:	
1.6 litre models	10.3:1
1.8 and 2.0 litre models	10.0:1
Compression pressure - at starter motor speed, engine fully warmed-up	Not available
Firing order	1-3-4-2 (No 1 cylinder at timing belt end)
Direction of crankshaft rotation	Clockwise (seen from right-hand side of vehicle)

Cylinder head

Hydraulic tappet bore inside diameter	28.395 to 28.425 mm
---------------------------------------	---------------------

Camshafts and hydraulic tappets

Camshaft bearing journal diameter	25.960 to 25.980 mm
Camshaft bearing journal-to-cylinder head running clearance	0.020 to 0.070 mm
Camshaft endfloat	0.080 to 0.220 mm
Hydraulic tappet diameter	28.400 mm

2A•2 In-car engine repair procedures

Lubrication

Engine oil type/specification	See Chapter 1
Engine oil capacity	See Chapter 1
Oil pressure	No information available at time of writing
Oil pump clearances	No information available at time of writing

Torque wrench settings

	Nm	lbf ft
Cylinder head cover bolts:		
Stage 1	2	1.5
Stage 2	7	5
Camshaft toothed pulley bolts	68	50
Camshaft bearing cap bolts:		
Stage 1	10	7
Stage 2	19	14
Cylinder head bolts:		
Stage 1	25	18
Stage 2	45	33
Stage 3	Angle-tighten a further 105°	
Timing belt cover fasteners:		
Upper-to-middle (outer) cover bolts	4	3
Cover-to-cylinder head or block bolts	7	5
Cover studs-to-cylinder head or block	9 to 11	6.5 to 8
Timing belt tensioner bolt	38	28
Timing belt tensioner backplate locating peg	8 to 11	6 to 8
Timing belt tensioner spring retaining pin	10	7
Timing belt guide pulley bolts	35 to 40	26 to 30
Water pump pulley bolts	10	7
Water pump bolts	See Chapter 3	
Auxiliary drivebelt idler pulley	48	35
Inlet manifold nuts and bolts	18	13
Alternator mounting bracket-to-cylinder block bolts	47	35
Cylinder head support plates:		
Front plate Torx screws - to power steering pump/air conditioning compressor mounting bracket and cylinder head	47	35
Rear plate/engine lifting eye - to alternator mounting bracket and cylinder head bolts	47	35
Front engine lifting eye bolt	16	12
Inlet and exhaust manifold studs-to-cylinder head	10 maximum	7 maximum
Exhaust manifold heat shield bolts:		
Shield-to-cylinder head	7	5
Shield/dipstick tube	10	7
Shield/coolant pipe-to-manifold	23	17
Exhaust manifold nuts	16	12
Air conditioning refrigerant pipe-to-exhaust manifold bolts	10	7
Crankshaft pulley bolt	108 to 115	80 to 85
Oil pump-to-cylinder block bolts	10	7
Oil pick-up pipe-to-pump screws	10	7
Oil baffle/pump pick-up pipe nuts	19	14
Oil filter adaptor-to-pump	18 to 25	13 to 18
Oil pressure warning light switch	27	20
Oil level sensor	27	20
Sump bolts	21 to 22	15 to 16
Coolant pipe-to-sump bolt	10	7
Flywheel/driveplate bolts	110 to 112	81 to 83
Crankshaft left-hand oil seal carrier bolts	22	16
Transmission-to-engine bolts	40	30
Engine/transmission front mounting:		
Mounting bracket-to-transmission	Not available	
Mounting-to-subframe bolts/nuts - stage 1	10	7
Mounting-to-subframe bolts/nuts - stage 2	48	35
Mounting centre bolt	120	89
Engine/manual transmission rear mounting:		
Mounting bracket-to-transmission 12 mm fasteners	78 to 84	58 to 62
Mounting bracket-to-transmission 10 mm fasteners	48	35
Mounting-to-subframe bolts and nut - stage 1	10	7
Mounting-to-subframe bolts and nut - stage 2	48	35
Mounting centre bolt	120	89

Torque wrench settings (continued)

	Nm	lbf ft
Engine/automatic transmission rear mounting:		
Mounting bracket-to-transmission	48 to 49	35 to 36
Mounting-to-subframe bolts - stage 1	10	7
Mounting-to-subframe bolts - stage 2	48	35
Mounting centre bolt	120	89
Engine/transmission left-hand mounting:		
Bracket-to-transmission nuts	83	61
Mounting centre bolt	Not available	
Mounting-to-body bolts	Not available	
Engine/transmission right-hand mounting:		
Bracket-to-engine and mounting nuts	83 to 90	61 to 66
Mounting-to-body bolts	84	62

Note: Refer to Part B of this Chapter for remaining torque wrench settings.

1 General information

How to use this Chapter

This Part of Chapter 2 is devoted to repair procedures possible while the engine is still installed in the vehicle, and includes only the Specifications relevant to those procedures. Since these procedures are based on the assumption that the engine is installed in the vehicle, if the engine has been removed from the vehicle and mounted on a stand, some of the preliminary dismantling steps outlined will not apply.

Information concerning engine/transmission removal and refitting, and engine overhaul, can be found in Part B of this Chapter, which also includes the Specifications relevant to those procedures.

General description - engine

The engine, also known by Ford's internal code name "Zetec" (formerly "Zeta"), is of four-cylinder, in-line type, mounted transversely at the front of the vehicle, with the (clutch and) transmission on its left-hand end (see illustrations).

Apart from the plastic timing belt covers and the cast-iron cylinder block/crankcase, all major engine castings are of aluminium alloy.

The crankshaft runs in five main bearings, the centre main bearing's upper half incorporating thrustwashers to control crankshaft endfloat. The connecting rods rotate on horizontally-split bearing shells at their big-ends. The pistons are attached to the connecting rods by gudgeon pins which are an interference fit in the connecting rod small-end eyes. The aluminium alloy pistons are fitted with three piston rings: two compression rings and an oil control ring. After manufacture, the cylinder bores and piston skirts are measured and classified into three grades, which must be carefully matched together, to ensure the correct piston/cylinder clearance; no oversizes are available to permit reboring.

The inlet and exhaust valves are each closed by coil springs; they operate in guides which are shrink-fitted into the cylinder head, as are the valve seat inserts.

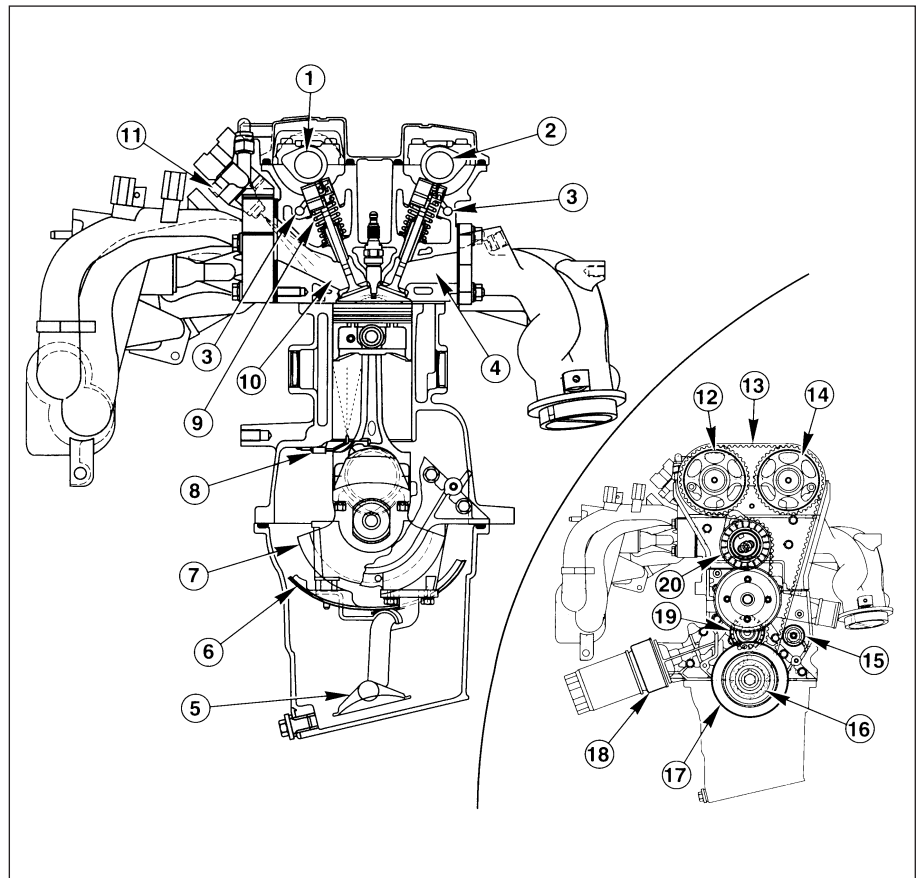

1.3A Longitudinal cross-section through engine - inset showing timing belt details

- | | | |
|---|------------------------------------|---------------------------------------|
| 1 Inlet camshaft | 9 Inlet valve | 15 Timing belt (front) guide pulley |
| 2 Exhaust camshaft | 10 Inlet port | 16 Crankshaft toothed pulley - behind |
| 3 Oil galleries | 11 Fuel injector | 17 Crankshaft pulley |
| 4 Exhaust port | 12 Inlet camshaft toothed pulley | 18 Oil cooler (where fitted) |
| 5 Oil strainer and pick-up pipe | 13 Timing belt | 19 Timing belt (rear) guide pulley |
| 6 Oil baffle | 14 Exhaust camshaft toothed pulley | 20 Timing belt tensioner |
| 7 Crankshaft | | |
| 8 Piston-cooling oil jet (where fitted) | | |

Both camshafts are driven by the same toothed timing belt, each operating eight valves via self-adjusting hydraulic tappets, thus eliminating the need for routine checking and adjustment of the valve clearances. Each camshaft rotates in five bearings that are line-

bored directly in the cylinder head and the (bolted-on) bearing caps; this means that the bearing caps are not available separately from the cylinder head, and must not be interchanged with caps from another engine.

The water pump is bolted to the right-hand

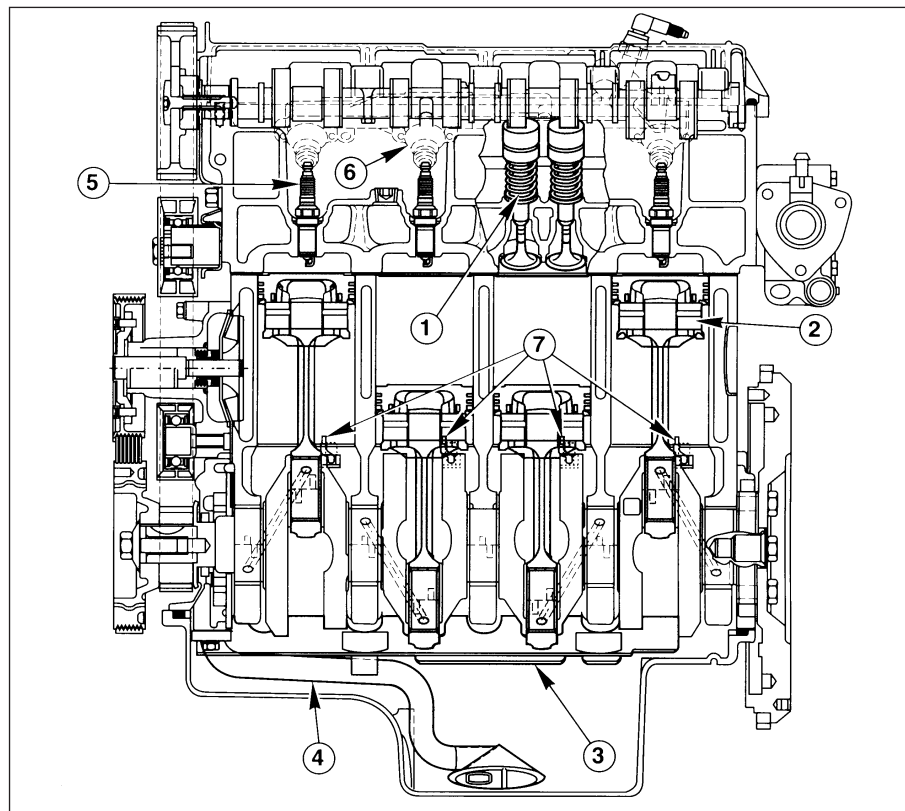

1.3B Lateral cross-section through engine

- | | | |
|-----------------|---------------------------------|--|
| 1 Exhaust valve | 4 Oil strainer and pick-up pipe | 6 Fuel injector |
| 2 Piston | 5 Spark plug | 7 Piston-cooling oil jets (where fitted) |
| 3 Oil baffle | | |

end of the cylinder block, inboard of the timing belt, and is driven with the power steering pump and alternator by a flat "polyvee"-type auxiliary drivebelt from the crankshaft pulley.

When working on this engine, note that Torx-type (both male and female heads) and hexagon socket (Allen head) fasteners are widely used; a good selection of bits, with the necessary adaptors, will be required, so that these can be unscrewed without damage and, on reassembly, tightened to the torque wrench settings specified.

General description - lubrication system

Lubrication is by means of an eccentric-rotor trochoidal pump, which is mounted on the crankshaft right-hand end, and draws oil through a strainer located in the sump. The pump forces oil through an externally-mounted full-flow cartridge-type filter - on some versions of the engine, an oil cooler is fitted to the oil filter mounting, so that clean oil entering the engine's galleries is cooled by the main engine cooling system. From the filter, the oil is pumped into a main gallery in the cylinder block/crankcase, from where it is distributed to the crankshaft (main bearings) and cylinder head (see illustration).

The big-end bearings are supplied with oil via internal drillings in the crankshaft. On some versions of the engine, each piston crown is cooled by a spray of oil directed at its underside by a jet. These jets are fed by passages off the crankshaft oil supply galleries, with spring-loaded valves to ensure that the jets open only when there is sufficient pressure to guarantee a good oil supply to the rest of the engine components; where the jets are not fitted, separate blanking plugs are provided, so that the passages are sealed, but can be cleaned at overhaul (see illustration).

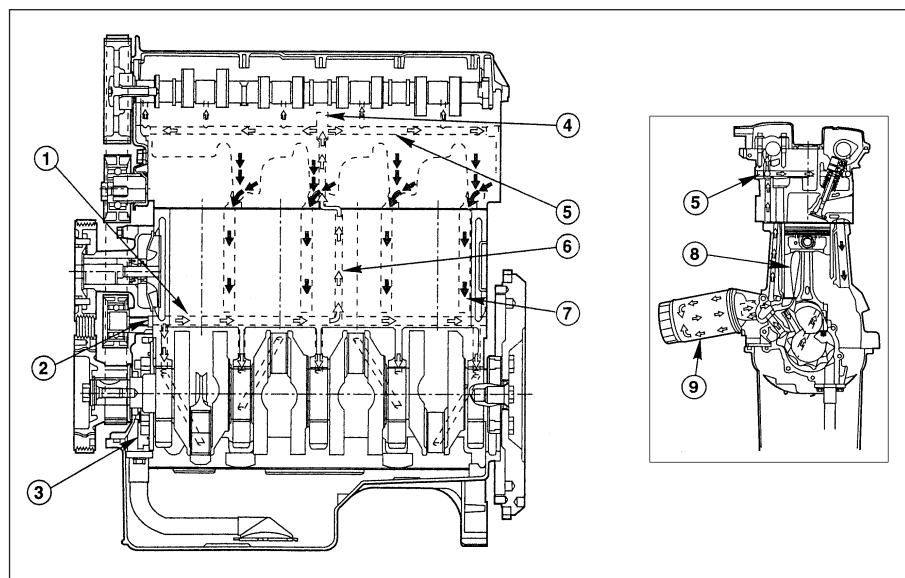

1.10 Engine lubrication system - inset showing longitudinal cross-section

- | | |
|-------------------------------------|---|
| 1 Main oil gallery | 6 Cylinder head oil supply |
| 2 From oil filter | 7 Oil return |
| 3 Oil pump | 8 Piston-cooling oil spray (where fitted) |
| 4 Cylinder head oil-retaining valve | 9 Oil filter - oil cooler not shown here |
| 5 Cylinder head oil gallery | |

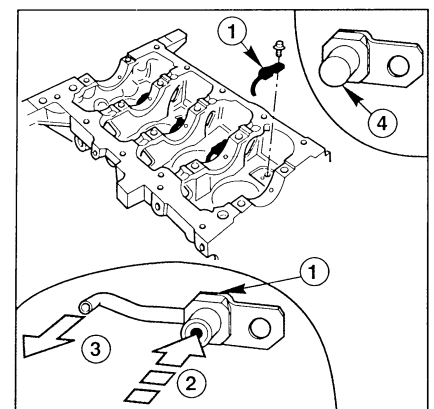

1.11 Piston-cooling oil jet details

- | |
|--|
| 1 Oil jets (when fitted) |
| 2 Oil flow - only when valve opens at set pressure |
| 3 Oil spray |
| 4 Blanking plug (when fitted) |

The cylinder head is provided with two oil galleries, one on the inlet side and one on the exhaust, to ensure constant oil supply to the camshaft bearings and hydraulic tappets. A retaining valve (inserted into the cylinder head's top surface, in the middle, on the inlet side) prevents these galleries from being drained when the engine is switched off. The valve incorporates a ventilation hole in its upper end, to allow air bubbles to escape from the system when the engine is restarted.

While the crankshaft and camshaft bearings and the hydraulic tappets receive a pressurised supply, the camshaft lobes and valves are lubricated by splash, as are all other engine components.

Valve clearances - general

It is necessary for a clearance to exist between the tip of each valve stem and the valve operating mechanism, to allow for the expansion of the various components as the engine reaches normal operating temperature.

On most older engine designs, this meant that the valve clearances (also known as "tappet" clearances) had to be checked and adjusted regularly. If the clearances were allowed to be too slack, the engine would be very noisy, its power output would suffer, and its fuel consumption would increase. If the clearances were allowed to be too tight, the engine's power output would be reduced, and the valves and their seats could be severely damaged.

The engines covered in this manual, however, employ hydraulic tappets which use the lubricating system's oil pressure automatically to take up the clearance between each camshaft lobe and its respective valve stem. Therefore, there is no need for regular checking and adjustment of the valve clearances, but it is essential that *only* good-quality oil of the recommended viscosity and specification is used in the engine, and that this oil is always changed at the recommended intervals. If this advice is not followed, the oilways and tappets may become clogged with particles of dirt, or deposits of burnt (inferior) engine oil, so that the system cannot work properly; ultimately, one or more of the tappets may fail, and expensive repairs may be required.

On starting the engine from cold, there will be a slight delay while full oil pressure builds up in all parts of the engine, especially in the tappets; the valve components, therefore, may well "rattle" for about 10 seconds or so, and then quieten. This is a normal state of affairs, and is nothing to worry about, provided that all tappets quieten quickly and stay quiet.

After the vehicle has been standing for several days, the valve components may "rattle" for longer than usual, as nearly all the oil will have drained away from the engine's top end components and bearing surfaces. While this is only to be expected, care must

be taken not to damage the engine under these circumstances - avoid high speed running until all the tappets are refilled with oil and operating normally. With the vehicle stationary, hold the engine at no more than a fast idle speed (maximum 2000 to 2500 rpm) for 10 to 15 seconds, or until the noise ceases. *Do not run the engine at more than 3000 rpm until the tappets are fully recharged with oil and the noise has ceased.*

If the valve components are thought to be noisy, or if a light rattle persists from the top end after the engine has warmed up to normal operating temperature, take the vehicle to a Ford dealer for expert advice. Depending on the mileage covered and the usage to which each vehicle has been put, some vehicles may be noisier than others; only a good mechanic experienced in these engines can tell if the noise level is typical for the vehicle's mileage, or if a genuine fault exists. If any tappet's operation is faulty, it must be renewed (Section 13).

2 Repair operations possible with the engine in the vehicle

The following major repair operations can be accomplished without removing the engine from the vehicle. However, owners should note that any operation involving the removal of the sump requires careful forethought, depending on the level of skill and the tools and facilities available; refer to the relevant text for details.

- (a) *Compression pressure - testing.*
- (b) *Cylinder head cover - removal and refitting.*
- (c) *Timing belt covers - removal and refitting.*
- (d) *Timing belt - renewal.*
- (e) *Timing belt tensioner and toothed pulleys - removal and refitting.*
- (f) *Camshaft oil seals - renewal.*
- (g) *Camshafts and hydraulic tappets - removal and refitting.*
- (h) *Cylinder head - removal, overhaul and refitting.*
- (i) *Cylinder head and pistons - decarbonising.*
- (j) *Sump - removal and refitting.*
- (k) *Crankshaft oil seals - renewal.*
- (l) *Oil pump - removal and refitting.*
- (m) *Piston/connecting rod assemblies - removal and refitting (but see note below).*
- (n) *Flywheel/driveplate - removal and refitting.*
- (o) *Engine/transmission mountings - removal and refitting.*

Clean the engine compartment and the exterior of the engine with some type of degreaser before any work is done. It will make the job easier, and will help to keep dirt out of the internal areas of the engine.

Depending on the components involved, it may be helpful to remove the bonnet, to improve access to the engine as repairs are performed (refer to Chapter 11 if necessary).

Cover the wings to prevent damage to the paint; special covers are available, but an old bedspread or blanket will also work.

If vacuum, exhaust, oil or coolant leaks develop, indicating a need for component/gasket or seal replacement, the repairs can generally be made with the engine in the vehicle. The intake and exhaust manifold gaskets, sump gasket, crankshaft oil seals and cylinder head gasket are all accessible with the engine in place.

Exterior components such as the intake and exhaust manifolds, the sump, the oil pump, the water pump, the starter motor, the alternator and the fuel system components can be removed for repair with the engine in place.

Since the cylinder head can be removed without lifting out the engine, camshaft and valve component servicing can also be accomplished with the engine in the vehicle, as can renewal of the timing belt and toothed pulleys.

In extreme cases caused by a lack of necessary equipment, repair or renewal of piston rings, pistons, connecting rods and big-end bearings is possible with the engine in the vehicle. However, this practice is not recommended, because of the cleaning and preparation work that must be done to the components involved, and because of the amount of preliminary dismantling work required - these operations are therefore covered in Part B of this Chapter.

3 Compression test - description and interpretation



1 When engine performance is down, or if misfiring occurs which cannot be attributed to the ignition or fuel systems, a compression test can provide diagnostic clues as to the engine's condition. If the test is performed regularly, it can give warning of trouble before any other symptoms become apparent.

2 The engine must be fully warmed-up to normal operating temperature, the oil level must be correct, the battery must be fully charged, and the spark plugs must be removed. The aid of an assistant will be required also.

3 Disable the ignition system by unplugging the ignition coil's electrical connector, and remove fuse 14 to disconnect the fuel pump.

4 Fit a compression tester to the No 1 cylinder spark plug hole - the type of tester which screws into the plug thread is to be preferred.

5 Have the assistant hold the throttle wide open and crank the engine on the starter motor; after one or two revolutions, the compression pressure should build up to a maximum figure, and then stabilise. Record the highest reading obtained.

6 Repeat the test on the remaining cylinders, recording the pressure developed in each.

7 At the time of writing, no compression

2A•6 In-car engine repair procedures

specifications were available from Ford, but a typical reading would be in excess of 12 bars. All cylinders should produce very similar pressures; any difference greater than 10% indicates the existence of a fault. Note that the compression should build up quickly in a healthy engine; low compression on the first stroke, followed by gradually-increasing pressure on successive strokes, indicates worn piston rings. A low compression reading on the first stroke, which does not build up during successive strokes, indicates leaking valves or a blown head gasket (a cracked head could also be the cause). Deposits on the undersides of the valve heads can also cause low compression.

8 If the pressure in any cylinder is considerably lower than the others, introduce a teaspoonful of clean oil into that cylinder through its spark plug hole, and repeat the test.

9 If the addition of oil temporarily improves the compression pressure, this indicates that bore or piston wear is responsible for the pressure loss. No improvement suggests that leaking or burnt valves, or a blown head gasket, may be to blame.

10 A low reading from two adjacent cylinders is almost certainly due to the head gasket having blown between them; the presence of coolant in the engine oil will confirm this.

11 If one cylinder is about 20 percent lower than the others and the engine has a slightly rough idle, a worn camshaft lobe or faulty hydraulic tappet could be the cause.

12 If the compression is unusually high, the combustion chambers are probably coated with carbon deposits. If this is the case, the cylinder head should be removed and decarbonised.

13 On completion of the test, refit the spark plugs, then reconnect the ignition system and fuel pump.

4 Top Dead Centre (TDC) for No 1 piston - locating



General

1 Top Dead Centre (TDC) is the highest point in its travel up-and-down its cylinder bore that each piston reaches as the crankshaft

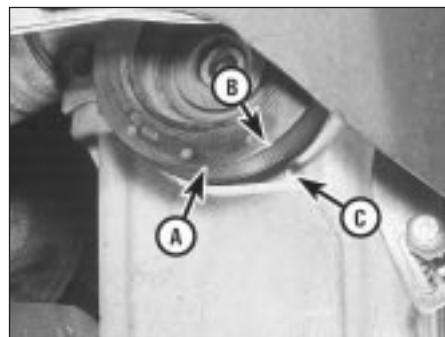

4.9A Do not use crankshaft pulley's first pair of notches "A" - align second pair of notches "B" with raised rib on sump "C" . . .

rotates. While each piston reaches TDC both at the top of the compression stroke and again at the top of the exhaust stroke, for the purpose of timing the engine, TDC refers to the piston position (usually No 1 piston) at the top of its compression stroke.

2 It is useful for several servicing procedures to be able to position the engine at TDC.

3 No 1 piston and cylinder are at the right-hand (timing belt) end of the engine (right-and left-hand are always quoted as seen from the driver's seat). Note that the crankshaft rotates clockwise when viewed from the right-hand side of the vehicle.

Locating TDC

4 Remove all the spark plugs (Chapter 1).

5 Disconnect both battery leads - see Chapter 5, Section 1 - unless the starter motor is to be used to turn the engine.

6 Apply the handbrake and ensure that the transmission is in neutral, then jack up the front right-hand side of the vehicle and support on an axle stand. Remove the roadwheel.

7 Remove the auxiliary drivebelt cover (see Chapter 1) to expose the crankshaft pulley and timing marks.

8 It is best to rotate the crankshaft using a spanner applied to the crankshaft pulley bolt; however, it is possible also to use the starter motor (switched on either by an assistant using the ignition key, or by using a remote starter switch) to bring the engine close to TDC, then finish with a spanner. If the starter is used, be sure to disconnect the battery leads immediately it is no longer required.

9 Note the two pairs of notches in the inner and outer rims of the crankshaft pulley. In the normal direction of crankshaft rotation (clockwise, seen from the right-hand side of the vehicle) the first pair of notches are irrelevant to the vehicles covered in this manual, while the second pair indicate TDC when aligned with the rear edge of the raised mark on the sump. Rotate the crankshaft clockwise until the second pair of notches align with the edge of the sump mark; use a straight edge extended out from the sump if greater accuracy is required (see illustrations).

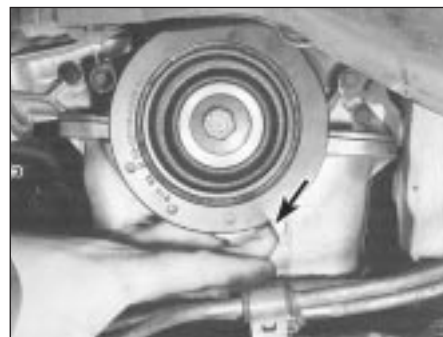

4.9B . . . using a straight edge extended out from the sump (arrowed) if greater accuracy is required

10 Nos 1 and 4 cylinders are now at TDC, one of them on the compression stroke. Remove the oil filler cap; if No 4 cylinder exhaust cam lobe is pointing to the rear of the vehicle and slightly downwards, it is No 1 cylinder that is correctly positioned. If the lobe is pointing horizontally forwards, rotate the crankshaft one full turn (360°) clockwise until the pulley notches align again, and the lobe is pointing to the rear and slightly down. No 1 cylinder will then be at TDC on the compression stroke.

11 Once No 1 cylinder has been positioned at TDC on the compression stroke, TDC for any of the other cylinders can then be located by rotating the crankshaft clockwise 180° at a time and following the firing order (see Specifications).

12 An alternative method of locating TDC is to remove the cylinder head cover (see Section 5) and to rotate the crankshaft (clockwise, as described in paragraph 8 above) until the inlet valves for the cylinder concerned have opened and just closed again. Insert a length of wooden dowel (approximately 150 mm/6 in long) or similar into the spark plug hole until it rests on the piston crown, and slowly further rotate the crankshaft (taking care not to allow the dowel to be trapped in the cylinder) until the dowel stops rising - the piston is now at the top of its compression stroke, and the dowel can be removed.

13 There is a "dead" area around TDC (as the piston stops rising, pauses and then begins to descend) which makes difficult the exact location of TDC by this method; if accuracy is required, either establish carefully the exact mid-point of the dead area, or refer to the timing marks (paragraph 9 above).

5 Cylinder head cover - removal and refitting



1 Unplug the two electrical connectors and disconnect the vacuum hose (where fitted), then remove the air cleaner assembly cover with the air mass meter, the resonator and the plenum chamber (see Chapter 4).

2 Disconnect the accelerator cable from the



5.4 Disconnecting crankcase breather hose from cylinder head cover union

throttle linkage as described in Chapter 4. Where fitted, disconnect also the cruise control actuator cable (see Chapter 12).

3 Remove the timing belt upper cover (see Section 9).

4 Disconnect the crankcase breather hose from the cylinder head cover union (see **illustration**).

5 Unplug the HT leads from the spark plugs and withdraw them, unclipping the leads from the cover.

6 Working progressively, unscrew the cylinder head cover retaining bolts, noting the spacer sleeve and rubber seal at each, then withdraw the cover (see **illustration**).

7 Discard the cover gasket; this *must* be renewed whenever it is disturbed. Check that the sealing faces are undamaged, and that the rubber seal at each retaining bolt is serviceable; renew any worn or damaged seals.

8 On refitting, clean the cover and cylinder head gasket faces carefully, then fit a new gasket to the cover, ensuring that it locates correctly in the cover grooves (see **illustration**).

9 Refit the cover to the cylinder head, then insert the rubber seal and spacer sleeve at each bolt location (see **illustration**). Start all bolts finger-tight, ensuring that the gasket remains seated in its groove.

10 Working in a diagonal sequence from the centre outwards, and in two stages (see Specifications), tighten the cover bolts to the specified torque wrench setting.

11 Refit the HT leads, clipping them into place so that they are correctly routed; each is numbered, and can also be identified by the numbering on its respective coil terminal.

12 Reconnect the crankcase breather hose, and refit the timing belt upper cover. Reconnect and adjust the accelerator cable, then refit the air cleaner assembly cover with the air mass meter, the resonator and the plenum chamber (see Chapter 4).

6 Inlet manifold - removal and refitting



Warning: Petrol is extremely flammable, so take extra precautions when disconnecting any part of the fuel system. Don't smoke, or allow naked flames or bare light bulbs in or near the work area. Don't work in a garage where a natural gas appliance (such as a clothes dryer or water heater) is installed. If you spill petrol on your skin, rinse it off immediately. Have a fire extinguisher rated for petrol fires handy, and know how to use it.

Removal

1 Park the vehicle on firm, level ground, apply the handbrake firmly, and slacken the nuts securing the right-hand front roadwheel.

2 Relieve the fuel system pressure (see Chapter 4).



5.6 Removing cylinder head cover



5.8 Ensure gasket is located correctly in cover groove



5.9 Ensure rubber seal is fitted to each cover bolt spacer, as shown



6.15 Alternator mounting bracket must be unbolted from rear of cylinder block to permit access to inlet manifold nut

3 Disconnect the battery negative (earth) lead - see Chapter 5, Section 1.

4 Unplugging the two electrical connectors and disconnecting the vacuum hose (where fitted), remove the air cleaner assembly cover with the air mass meter, the resonator and the plenum chamber (see Chapter 4).

5 Disconnect the accelerator cable from the throttle linkage as described in Chapter 4 - where fitted, disconnect also the cruise control actuator cable (see Chapter 12).

6 Disconnect the crankcase breather hose from the cylinder head cover union.

7 Unbolt the upper part of the exhaust manifold heat shield; unclip the coolant hose to allow it to be withdrawn. Slacken the sleeve nut securing the EGR pipe to the manifold, remove the two screws securing the pipe to the ignition coil bracket, then unscrew the sleeve nut securing the pipe to the EGR valve - see Chapter 6 for full details if required.

8 Remove the two screws securing the wiring "rail" to the top of the manifold - this is simply so that it can be moved as required to reach the manifold bolts. Unplug their electrical connectors to disconnect the camshaft position sensor and the coolant temperature sensor, then unclip the wiring from the ignition coil bracket, and secure it to the manifold.

9 Remove the three screws securing the wiring "rail" to the rear of the manifold. Releasing its wire clip, unplug the large electrical connector (next to the fuel pressure regulator) to disconnect the wiring of the

manifold components from the engine wiring loom.

10 Marking or labelling them as they are unplugged, disconnect the vacuum hoses as follows:

- One from the rear of the throttle housing (only the one hose - there is no need to disconnect the second hose running to the fuel pressure regulator).
- One from the union on the manifold's left-hand end.
- The braking system vacuum servo unit hose (see Chapter 9 for details).
- One from the Exhaust Gas Recirculation (EGR) valve.

11 Equalise the pressure in the fuel tank by removing the filler cap, then undo the fuel feed and return lines connecting the engine to the chassis (see Chapter 4). Plug or cap all open fittings.

12 Unbolt the power steering high-pressure pipe and the earth lead from the cylinder head rear support plate/engine lifting eye, then unscrew the bolt securing the support plate/lifting eye to the alternator mounting bracket.

13 Unscrew the six nuts securing the engine/transmission right-hand mounting bracket, then withdraw the bracket.

14 Remove the alternator (see Chapter 5).

15 Unbolt the alternator mounting bracket from the rear of the cylinder block and withdraw it, together with the cylinder head rear support plate/engine lifting eye (see **illustration**).



6.16 Withdrawing inlet manifold - take care not to damage delicate components

16 Unscrew the bolts and nuts securing the manifold to the cylinder head and withdraw it (see illustration). Take care not to damage vulnerable components such as the EGR pipe and valve as the manifold assembly is manoeuvred out of the engine compartment.

Refitting

17 Refitting is the reverse of the removal procedure, noting the following points:

- (a) When using a scraper and solvent to remove all traces of old gasket material and sealant from the manifold and cylinder head, be careful to ensure that you do not scratch or damage the material of either; the cylinder head is of aluminium alloy, while the manifold is a plastics moulding - any solvents used must be suitable for this application. If the gasket was leaking, have the mating surfaces checked for warpage at an automotive machine shop. While it may be possible to have the cylinder head gasket surface skimmed if necessary, to remove any distortion, the manifold must be renewed if it is found to be warped, cracked - check with special care around the mounting points for components such as the idle speed control valve and EGR pipe - or otherwise faulty.
- (b) Provided the relevant mating surfaces are clean and flat, a new gasket will be

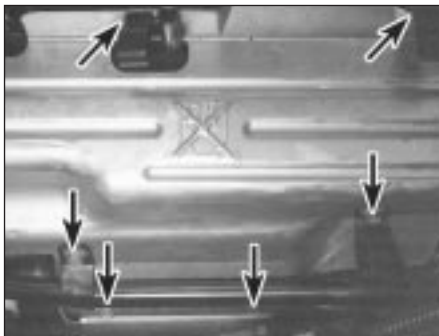

7.5 Exhaust manifold heat shield upper part securing bolts (arrowed)



6.17A Always renew inlet manifold gasket - do not rely on sealants

sufficient to ensure the joint is gas-tight. **Do not** use any kind of silicone-based sealant on any part of the fuel system or inlet manifold.

- (c) Fit a new gasket, then locate the manifold on the head and install the nuts and bolts (see illustration).
- (d) Tighten the nuts/bolts in three or four equal steps to the torque listed in this Chapter's Specifications. Work from the centre outwards, to avoid warping the manifold.
- (e) Refit the remaining parts in the reverse order of removal - tighten all fasteners to the torque wrench settings specified.
- (f) When reassembling the engine/transmission right-hand mounting, renew the self-locking nuts, and do not allow the mounting to twist as the middle two of the bracket's six nuts are tightened.
- (g) Before starting the engine, check the accelerator cable for correct adjustment and the throttle linkage for smooth operation.
- (h) When the engine is fully warmed up, check for signs of fuel, intake and/or vacuum leaks (see illustration).
- (i) Road test the vehicle, and check for proper operation of all disturbed components.

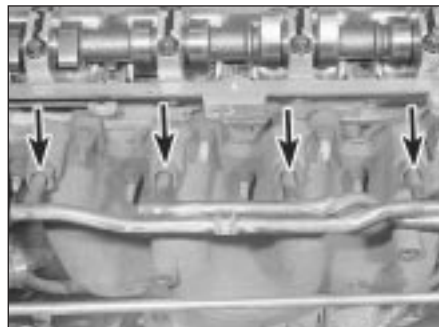

7.7 Pulse-air system (sleeve nuts arrowed) need not be removed unless required - assembly can be withdrawn with exhaust manifold

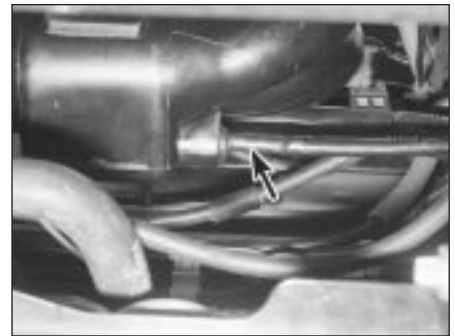

6.17B Check all disturbed components - braking system vacuum servo unit hose (arrowed) shown here - for leaks on reassembly

7 Exhaust manifold - removal, inspection and refitting



Warning: The engine must be completely cool before beginning this procedure.

Note: In addition to the new gasket and any other parts, tools or facilities needed to carry out this operation, a new plastic guide sleeve will be required on reassembly.

Removal

- 1 Disconnect the battery negative (earth) lead - see Chapter 5, Section 1.
- 2 Unbolt the resonator support bracket from the engine compartment front crossmember, slacken the two clamp screws securing the resonator to the air mass meter and plenum chamber hoses, then swing the resonator up clear of the thermostat housing (see Chapter 4).
- 3 Drain the cooling system (see Chapter 1).
- 4 Disconnect the coolant hose and the coolant pipe/hose from the thermostat housing; secure them clear of the working area.
- 5 Unbolt the exhaust manifold heat shield, and withdraw both parts of the shield (see illustration). Apply penetrating oil to the EGR pipe sleeve nut, and to the exhaust manifold mounting nuts (also to the pulse-air system sleeve nuts, if they are to be unscrewed).
- 6 Unscrew the sleeve nut securing the EGR pipe to the manifold, remove the two screws securing the pipe to the ignition coil bracket, then slacken the sleeve nut securing the pipe to the EGR valve - see Chapter 6 for full details if required.
- 7 While the manifold can be removed with the pulse-air system components attached - unbolt the filter housing and disconnect its vacuum hose if this is to be done - it is easier to remove the pulse-air assembly first, as described in Chapter 6 (see illustration).
- 8 Unplugging the oxygen sensor electrical connector to avoid straining its wiring, unscrew the nuts to disconnect the exhaust system front downpipe from the manifold (see Chapter 4).

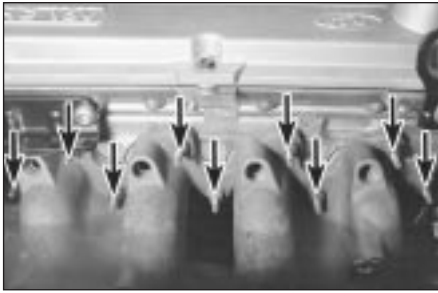

7.9A Unscrew nuts (arrowed) to remove exhaust manifold . . .

9 Remove the nuts and detach the manifold and gasket (see illustration). Take care not to damage vulnerable components such as the EGR pipe as the manifold assembly is manoeuvred out of the engine compartment. When removing the manifold with the engine in the vehicle, additional clearance can be obtained by unscrewing the studs from the cylinder head; a female Torx-type socket will be required (see illustration).

10 Always fit a new gasket on reassembly, to carefully-cleaned components (see below). Do not attempt to re-use the original gasket.

Inspection

11 Use a scraper to remove all traces of old gasket material and carbon deposits from the manifold and cylinder head mating surfaces. If the gasket was leaking, have the manifold checked for warpage at an automotive machine shop, and have it resurfaced if necessary.



Caution: When scraping, be very careful not to gouge or scratch the delicate aluminium alloy cylinder head.

12 Provided both mating surfaces are clean and flat, a new gasket will be sufficient to ensure the joint is gas-tight. Do not use any kind of exhaust sealant upstream of the catalytic converter.

13 Note that the downpipe is secured to the manifold by two bolts, with a coil spring, spring seat and self-locking nut on each. On refitting, tighten the nuts until they stop on the



7.13B Renew exhaust system downpipe-to-manifold gasket to prevent leaks



7.9B . . . studs can be unscrewed also, if required, to provide additional working space

bolt shoulders; the pressure of the springs will then suffice to make a leakproof joint (see illustrations).

14 Do not overtighten the nuts to cure a leak - the bolts will shear; renew the gasket and the springs if a leak is found. The bolts themselves are secured by spring clips to the manifold, and can be renewed easily if damaged (see illustration).

Refitting

15 Refitting is the reverse of the removal procedure, noting the following points:

- Position a new gasket over the cylinder head studs, and fit a new plastic guide sleeve to the stud nearest to the thermostat housing, so that the manifold will be correctly located (see illustration). Do not refit the manifold without this sleeve.
- Refit the manifold, and finger-tighten the mounting nuts.
- Working from the centre out, and in three or four equal steps, tighten the nuts to the torque wrench setting given in the Specifications Section of this Chapter.
- Refit the remaining parts in the reverse order of removal. Tighten all fasteners to the specified torque wrench settings.
- Refill the cooling system (see Chapter 1).
- Run the engine, and check for exhaust leaks. Check the coolant level when fully warmed-up to normal operating temperature.

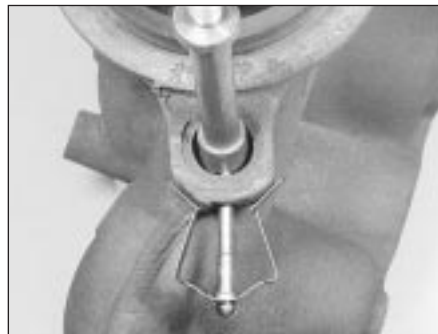

7.14 Release spring clip to extract securing bolt from manifold, when required



7.13A Showing exhaust downpipe-to-manifold securing bolts - note coil spring, and shoulder on bolt

8 Crankshaft pulley - removal and refitting



1 Remove the auxiliary drivebelt - either remove the drivebelt completely, or just secure it clear of the crankshaft pulley, depending on the work to be carried out (see Chapter 1).

2 If necessary, rotate the crankshaft until the timing marks align (see Section 4).

3 The crankshaft must now be locked to prevent its rotation while the pulley bolt is unscrewed. Proceed as follows:

- If the engine/transmission is still installed in the vehicle:
 - If the vehicle is fitted with manual transmission, select top gear, and have an assistant apply the brakes hard.
 - If the vehicle is fitted with automatic transmission, unbolt the small metal cover plate from the sump, and use a large screwdriver or similar to lock the driveplate ring gear teeth while an assistant slackens the pulley bolt; take care not to damage the teeth or the surrounding castings when using this method.
- If the engine/transmission has been removed but not yet separated:
 - If the vehicle is fitted with manual transmission, remove the starter motor (see Chapter 5) and lock the flywheel

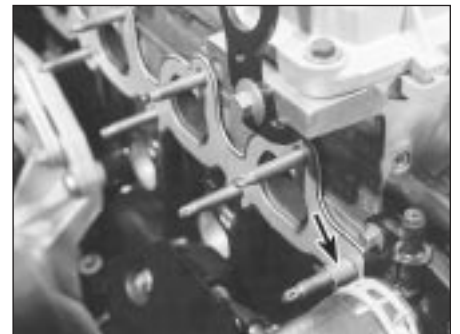

7.15 Fit plastic guide sleeve to stud arrowed when refitting exhaust manifold



8.4A Unscrew pulley bolt to release crankshaft pulley



8.4B Ensure pulley is located on crankshaft Woodruff key on reassembly



9.1 Remove bolts (arrowed) to release timing belt upper cover

using the method outlined in (2) above.
 (2) If the vehicle is fitted with automatic transmission, see (2) above.
 (c) If the engine/transmission has been removed and separated, use the method shown in illustration 21.11.
 4 Unscrew the pulley bolt and remove the pulley (see illustrations).
 5 Refitting is the reverse of the removal procedure; ensure that the pulley's keyway is aligned with the crankshaft's locating key, and tighten the pulley bolt to the specified torque wrench setting.

9 Timing belt covers - removal and refitting

Upper cover
 1 Unscrew the cover's two mounting bolts and withdraw it (see illustration).
 2 Refitting is the reverse of the removal procedure; ensure the cover edges engage correctly with each other, and note the torque wrench setting specified for the bolts.

Middle cover
 3 Unscrew the six nuts securing the engine/transmission right-hand mounting bracket, then withdraw the bracket.
 4 Slacken the water pump pulley bolts.
 5 Remove the timing belt upper cover (see paragraph 1 above).
 6 Remove the auxiliary drivebelt (see Chapter 1).
 7 Unbolt and remove the water pump pulley (see illustration).
 8 Unscrew the middle cover fasteners (one bolt at the front, one at the lower rear, one stud at the top rear) and withdraw the cover (see illustration).

9 Refitting is the reverse of the removal procedure. Ensure the cover edges engage correctly with each other, and note the torque wrench settings specified for the various fasteners. When reassembling the engine/transmission right-hand mounting, renew the self-locking nuts, and do not allow the mounting to twist as the middle two of the bracket's six nuts are tightened.

Lower cover
 10 Remove the crankshaft pulley (see Section 8).
 11 Unscrew the cover's three securing bolts and withdraw it (see illustration).
 12 Refitting is the reverse of the removal procedure; ensure the cover edges engage correctly with each other, and note the torque wrench settings specified for the various fasteners.

Inner shield
 13 Remove the timing belt, its tensioner components and the camshaft toothed pulleys (see Sections 10 and 11).
 14 The shield is secured to the cylinder head by two bolts at the top, and by two studs

lower down; unscrew these and withdraw the shield (see illustration).
 15 Refitting is the reverse of the removal procedure; note the torque wrench settings specified for the various fasteners.

10 Timing belt - removal, refitting and adjustment

Note: To carry out this operation, a new timing belt (where applicable), a new cylinder head cover gasket, and some special tools (see text) will be required. If the timing belt is being removed for the first time since the vehicle left the factory, a tensioner spring and retaining pin must be obtained for fitting on reassembly.



9.7 Slacken water pump pulley bolts and remove pulley

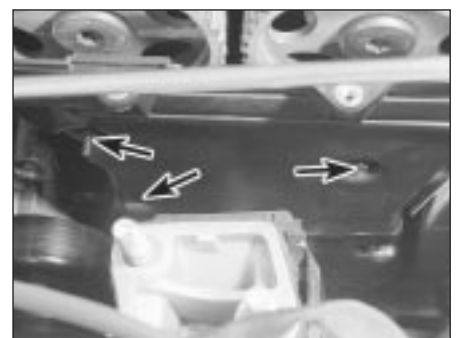

9.8 Remove fasteners (arrowed) to release timing belt middle cover

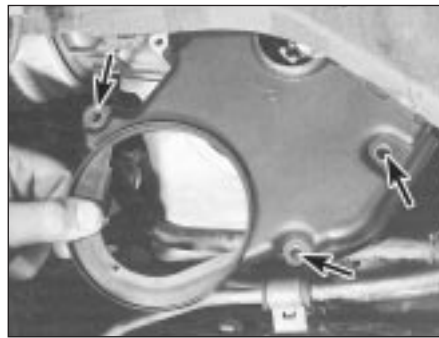

9.11 Removing timing belt lower cover - bolt locations arrowed

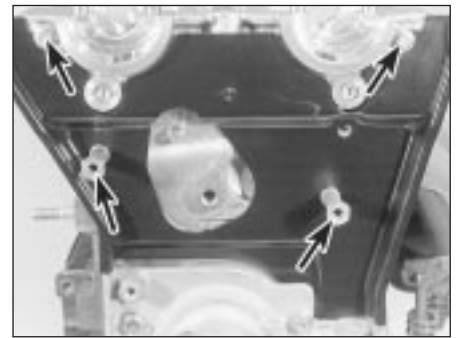

9.14 Timing belt inner shield fasteners (arrowed)

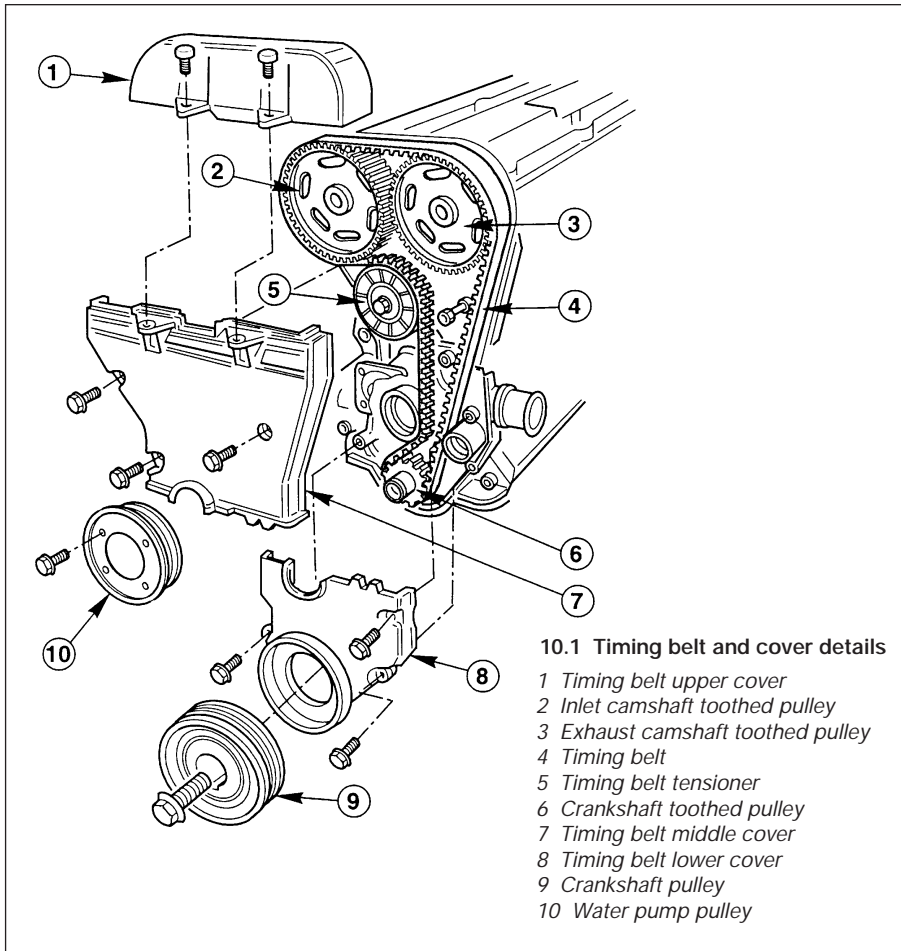

9 Unbolt and remove the water pump pulley and the auxiliary drivebelt idler pulley.

10 Obtain Ford service tool 21-162, or fabricate a substitute from a strip of metal 5 mm thick (while the strip's thickness is critical, its length and width are not, but should be approximately 180 to 230 mm by 20 to 30 mm). Check that Nos 1 and 4 cylinders are at Top Dead Centre (TDC) - No 1 on the compression stroke - by resting this tool on the cylinder head mating surface, and sliding it into the slot in the left-hand end of both camshafts (see illustration). The tool should slip snugly into both slots while resting on the cylinder head mating surface; if one camshaft is only slightly out of alignment, it is permissible to use an open-ended spanner to rotate the camshaft gently and carefully until the tool will fit.

11 If both camshaft slots (they are machined significantly off-centre) are below the level of the cylinder head mating surface, rotate the crankshaft through one full turn clockwise and fit the tool again; it should now fit as described in the previous paragraph.

12 With the camshaft aligning tool remaining in place, remove the crankshaft pulley. Do not use the locked camshafts to prevent the crankshaft from rotating - use only the locking methods described in Section 8.

13 Remove the timing belt lower and middle covers (see Section 9).

14 With the camshaft aligning tool still in place, slacken the tensioner bolt, and use an Allen key inserted into its centre to rotate the tensioner clockwise as far as possible away from the belt; retighten the bolt to secure the tensioner clear of the timing belt (see illustration).

15 If the timing belt is to be re-used, use white paint or similar to mark its direction of rotation, and note from the manufacturer's markings which way round it is fitted. Withdraw the belt (see illustration). Do not rotate the crankshaft until the timing belt is refitted.

16 If the belt is being removed for reasons other than routine renewal, check it carefully for any signs of uneven wear, splitting, cracks (especially at the roots of the belt teeth) or

1 With the vehicle parked on firm level ground, open the bonnet and disconnect the battery negative (earth) lead - see Chapter 5, Section 1 (see illustration).

2 Unbolt the power steering high-pressure pipe from the cylinder head rear support plate/engine lifting eye, and from the front support plate/pump bracket.

3 Unscrew the six nuts securing the engine/transmission right-hand mounting bracket, then withdraw the bracket.

4 Slacken the water pump pulley bolts.

5 Remove the cylinder head cover (see Section 5).

6 Remove the spark plugs, covering their holes with clean rag, to prevent dirt or other foreign bodies from dropping in (see Chapter 1).

7 Remove the auxiliary drivebelt (see Chapter 1).

8 Rotate the crankshaft clockwise until the second pair of notches in the pulley rim align with the edge of the sump mark, so that Nos 1 and 4 cylinders are at TDC (see Section 4).



10.10 Fit camshaft aligning tool to ensure engine is locked with Nos 1 and 4 cylinders at TDC

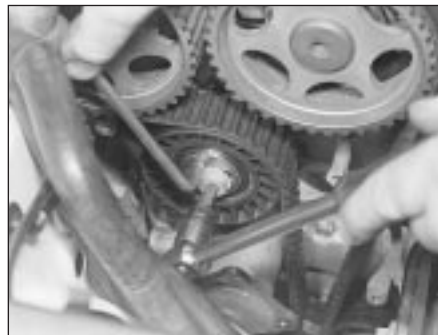

10.14 Slacken tensioner bolt, and use Allen key to rotate tensioner away from timing belt . . .



10.15 . . . then withdraw timing belt



10.19A Fitting tensioner spring retaining pin

contamination with oil or coolant. Renew the belt if there is the slightest doubt about its condition. As a safety measure, the belt must be renewed as a matter of course at the intervals given in Chapter 1; if its history is unknown, the belt should be renewed irrespective of its apparent condition whenever the engine is overhauled. Similarly, check the tensioner spring (where fitted), renewing it if there is any doubt about its condition. Check also the toothed pulleys for signs of wear or damage, and ensure that the tensioner and guide pulleys rotate smoothly on their bearings; renew any worn or damaged components. If signs of oil or coolant contamination are found, trace the source of the leak and rectify it, then wash down the engine timing belt area and related components, to remove all traces of oil or coolant.

17 On reassembly, temporarily refit the crankshaft pulley, to check that the pulley notches and sump rib are aligned as described in paragraph 8 above, then ensure that both camshafts are aligned at TDC by the special tool (paragraph 10). If the engine is being reassembled after major dismantling, both camshaft toothed pulleys should be free to rotate on their respective camshafts; if the timing belt alone is being renewed, both pulleys should still be securely fastened.

18 A holding tool will be required to prevent the camshaft toothed pulleys from rotating while their bolts are slackened and retightened; either obtain Ford service tool



10.22 Slacken tensioner bolt to give initial belt tension



10.19B Hook spring onto tensioner and refit as shown - engage tensioner backplate on locating peg (arrowed) . . .

15-030A, or fabricate a substitute as follows. Find two lengths of steel strip, one approximately 600 mm long and the other about 200 mm, and three bolts with nuts and washers; one nut and bolt forming the pivot of a forked tool, with the remaining nuts and bolts at the tips of the "forks", to engage with the pulley spokes as shown in the accompanying illustrations. **Note:** *Do not use the camshaft aligning tool (whether genuine Ford or not) to prevent rotation while the camshaft toothed pulley bolts are slackened or tightened; the risk of damage to the camshaft concerned and to the cylinder head is far too great. Use only a forked holding tool applied directly to the pulleys, as described.*

19 If it is being fitted for the first time, screw the timing belt tensioner spring retaining pin into the cylinder head, tightening it to the specified torque wrench setting. Unbolt the tensioner, hook the spring on to the pin and the tensioner backplate, then refit the tensioner, engaging its backplate on the locating peg (see illustrations).

20 In all cases, slacken the tensioner bolt (if necessary), and use an Allen key inserted into its centre to rotate the tensioner clockwise as far as possible against spring tension, then retighten the bolt to secure the tensioner (see illustration).

21 Fit the timing belt; if the original is being refitted, ensure that the marks and notes made on removal are followed, so that the belt is refitted the same way round, and to run in the same direction. Starting at the



10.25 Using forked holding tool while camshaft toothed pulley bolt is tightened



10.20 . . . then use Allen key to position tensioner so that timing belt can be refitted

crankshaft toothed pulley, work anti-clockwise around the camshaft toothed pulleys and tensioner, finishing off at the rear guide pulley. The front run, between the crankshaft and the exhaust camshaft toothed pulleys, *must* be kept taut, without altering the position either of the crankshaft or of the camshaft(s) - if necessary, the position of the camshaft toothed pulleys can be altered by rotating each on its camshaft (which remains fixed by the aligning tool). Where the pulley is still fastened, use the holding tool described in paragraph 18 above to prevent the pulley from rotating while its retaining bolt is slackened - the pulley can then be rotated on the camshaft until the belt will slip into place; retighten the pulley bolt.

22 When the belt is in place, slacken the tensioner bolt gently until the spring pulls the tensioner against the belt; the tensioner should be retained correctly against the timing belt inner shield and cylinder head, but must be just free to respond to changes in belt tension (see illustration).

23 Tighten both camshaft toothed pulley bolts (or check that they are tight, as applicable) and remove the camshaft aligning tool. Temporarily refit the crankshaft pulley, and rotate the crankshaft through two full turns clockwise to settle and tension the timing belt, returning the crankshaft (pulley notches) to the position described in paragraph 8 above. Refit the camshaft aligning tool; it should slip into place as described in paragraph 10. If all is well, proceed to paragraph 26 below.

24 If one camshaft is only just out of line, fit the forked holding tool to its toothed pulley, adjust its position as required, and check that any slack created has been taken up by the tensioner; rotate the crankshaft through two further turns clockwise, and refit the camshaft aligning tool to check that it now fits as it should. If all is well, proceed to paragraph 26 below.

25 If either camshaft is significantly out of line, use the holding tool described in paragraph 18 above to prevent its pulley from rotating while its retaining bolt is slackened - the camshaft can then be rotated (gently and carefully, using an open-ended spanner) until



10.26 When setting is correct, tighten tensioner bolt to specified torque wrench setting

the camshaft aligning tool will slip into place; take care not to disturb the relationship of the pulley to the timing belt. Without disturbing the pulley's new position on the camshaft, tighten the pulley bolt to its specified torque wrench setting (see illustration). Remove the camshaft aligning tool, rotate the crankshaft through two further turns clockwise and refit the tool to check that it now fits as it should.

26 When the timing belt has been settled at its correct tension, and the camshaft aligning tool fits correctly when the crankshaft pulley notches are exactly aligned, tighten the tensioner bolt to its specified torque wrench setting (see illustration). Fitting the forked holding tool to the spokes of each pulley in turn, check that the pulley bolts are tightened to their specified torque wrench setting. Remove the camshaft aligning tool, rotate the crankshaft through two further turns clockwise, and refit the tool to make a final check that it fits as it should.

27 The remainder of the reassembly procedure is the reverse of removal, noting the following points:

- (a) Tighten all fasteners to the torque wrench settings specified.
- (b) When reassembling the engine/transmission right-hand mounting, renew the self-locking nuts, and do not allow the mounting to twist as the middle two of the bracket's six nuts are tightened.



11.3 Removing timing belt tensioner

11 Timing belt tensioner and toothed pulleys - removal, inspection and refitting

Tensioner

Note: If the tensioner is being removed for the first time since the vehicle left the factory, a tensioner spring and retaining pin must be obtained for fitting on reassembly.

1 While it is possible to reach the tensioner once the timing belt upper and middle covers only have been removed (see Section 9), the whole procedure outlined below must be followed, to ensure that the valve timing is correctly reset once the belt's tension has been disturbed.

2 Release the tension from the timing belt as described in Section 10, paragraphs 1 to 14.

3 Unscrew the tensioner bolt and withdraw the tensioner, unhooking the spring, if fitted (see illustration). Check the tensioner and spring as described in paragraph 16 of Section 10.

4 On reassembly, if it is being fitted for the first time, screw the timing belt tensioner spring retaining pin into the cylinder head, tightening it to the specified torque wrench setting. Hook the spring onto the pin and the tensioner backplate, then refit the tensioner, engaging its backplate on the locating peg.

5 Use an Allen key inserted into its centre to rotate the tensioner clockwise as far as possible against spring tension, then tighten the bolt to secure the tensioner.

6 Reassemble, checking the camshaft alignment (valve timing) and setting the timing belt tension, as described in paragraphs 22 to 27 of Section 10.

Camshaft and crankshaft toothed pulleys

7 While it may be possible to remove any of these pulleys once their respective covers have been removed, the complete timing belt removal/refitting procedure (see Section 10) must be followed, to ensure that the valve timing is correctly reset once the belt's tension has been disturbed.



11.8 Note "FRONT" marking on outside face of crankshaft toothed pulley - note which way round thrustwasher behind is fitted

8 With the timing belt removed, the camshaft toothed pulleys can be detached once their retaining bolts have been unscrewed as described in paragraphs 18 and 21 of Section 10. The crankshaft toothed pulley can be pulled off the end of the crankshaft once the crankshaft (grooved) pulley and the timing belt have been removed. Note the "FRONT" marking identifying the pulley's outboard face, and the thrustwasher behind it; note which way round the thrustwasher is fitted (see illustration). Note the pulley-locating Woodruff key; if this is loose, it should be removed for safe storage with the pulley.

9 Check the pulleys as described in paragraph 16 of Section 10.

10 Refitting is the reverse of the removal procedure.

Timing belt guide pulleys

11 Remove the timing belt covers (see Section 9).

12 Unbolt and withdraw the pulley(s); check their condition as described in paragraph 16 of Section 10.

13 Refitting is the reverse of the removal procedure; tighten the pulley bolts to the specified torque wrench setting (see illustration).

12 Camshaft oil seals - renewal

Note: While it is possible to reach either oil seal, once the respective toothed pulley has been removed (see Section 11) to allow the seal to be prised out, this procedure is not recommended. Not only are the seals very soft, making this difficult to do without risk of damage to the seal housing, but it would be very difficult to ensure that the valve timing and the timing belt's tension, once disturbed, are correctly reset. Owners are advised to follow the whole procedure outlined below.

1 Release the tension from the timing belt as described in Section 10, paragraphs 1 to 14.

Note: If the timing belt is found to be contaminated by oil, remove it completely as described, then renew the oil seal (see below). Wash down the engine timing belt area and all



11.13 Tighten timing belt guide pulley bolts to specified torque settings on refitting



12.5 Using socket and toothed pulley bolt to install camshaft oil seal



12.6 Alternatively, seal can be inserted when camshaft bearing cap is unbolted



13.3 Using forked holding tool while camshaft toothed pulley bolt is slackened

related components, to remove all traces of oil. Fit a new belt on reassembly.

2 If the timing belt is still clean, slip it off the toothed pulley, taking care not to twist it too sharply; use the fingers only to handle the belt. *Do not* rotate the crankshaft until the timing belt is refitted. Cover the belt, and secure it so that it is clear of the working area and cannot slip off the remaining toothed pulley.

3 Unfasten the pulley bolt and withdraw the pulley (see Section 11).

4 Unbolt the camshaft right-hand bearing cap, and withdraw the defective oil seal. Clean the seal housing, and polish off any burrs or raised edges, which may have caused the seal to fail in the first place.

5 To fit a new seal, Ford recommend the use of their service tool 21-009B, with a bolt (10 mm thread size, 70 mm long) and a washer, to draw the seal into place when the camshaft bearing cap is bolted down; a substitute can be made using a suitable socket (see illustration). Grease the seal lips and periphery to ease installation, and draw the seal into place until it is flush with the housing/bearing cap outer edge. Refit the bearing cap, using sealant and tightening the cap bolts as described in Section 13.

6 For most owners, the simplest answer will be to grease the seal lips, and to slide it on to the camshaft (until it is flush with the

housing's outer edge). Refit the bearing cap, using sealant and tightening the cap bolts as described in Section 13 (see illustration). Take care to ensure that the seal remains absolutely square in its housing, and is not distorted as the cap is tightened down.

7 Refit the pulley to the camshaft, tightening the retaining bolt loosely, then slip the timing belt back onto the pulley (refer to paragraphs 18 and 21 of Section 10) and tighten the bolt securely.

8 The remainder of the reassembly procedure, including checking the camshaft alignment (valve timing) and setting the timing belt tension, is as described in paragraphs 22 to 27 of Section 10.

13 Camshafts and hydraulic tappets - removal, inspection and refitting



Removal

1 Release the tension from the timing belt as described in Section 10, paragraphs 1 to 14.

2 Either remove the timing belt completely (Section 10, paragraphs 15 and 16) or slip it off the camshaft toothed pulleys, taking care not to twist it too sharply; use the fingers only to handle the belt. Cover the belt, and secure it so that it is clear of the working area. *Do not* rotate the crankshaft until the timing belt is refitted.

3 Unfasten the pulley bolts as described in Section 10, paragraphs 18 and 21, and withdraw the pulleys; while both are the same and could be interchanged, it is good working practice to mark them so that each is refitted only to its original location (see illustration).

4 Working in the sequence shown, slacken progressively, by half a turn at a time, the camshaft bearing cap bolts (see illustration). Work only as described, to release gradually and evenly the pressure of the valve springs on the caps.

5 Withdraw the caps, noting their markings and the presence of the locating dowels, then remove the camshafts and withdraw their oil seals. The inlet camshaft can be identified by the reference lobe for the camshaft position sensor; therefore, there is no need to mark the camshafts (see illustrations).

6 Obtain sixteen small, clean containers, and number them 1 to 16. Using a rubber sucker, withdraw each hydraulic tappet in turn, invert it to prevent oil loss, and place it in its respective container, which should then be filled with clean engine oil (see illustrations). Do not interchange the hydraulic tappets, or the rate of wear will be much increased. Do not allow them to lose oil, or they will take a long time to refill on restarting the engine, resulting in incorrect valve clearances.

Inspection

7 With the camshafts and hydraulic tappets removed, check each for signs of obvious

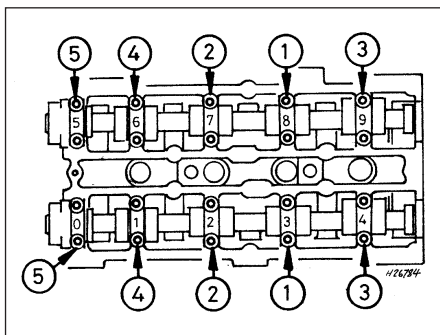

13.4 Camshaft bearing cap slackening sequence

Note: View from front of vehicle, showing bearing cap numbers



13.5A Note locating dowels when removing camshaft bearing caps



13.5B Inlet camshaft has lobe for camshaft position sensor



13.6A Removing hydraulic tappets

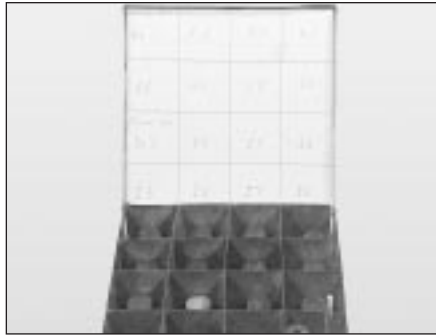

13.6B Hydraulic tappets must be stored as described in text

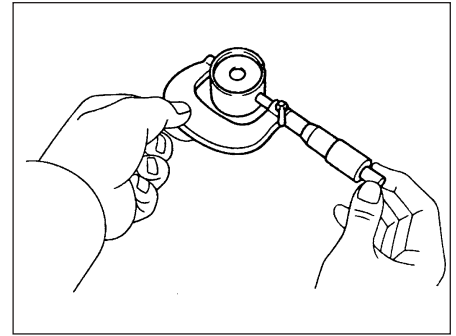

13.8 Use a micrometer to measure diameter of hydraulic tappets

wear (scoring, pitting etc) and for ovality, and renew if necessary.

8 Measure the outside diameter of each tappet (see illustration) - take measurements at the top and bottom of each tappet, then a second set at right-angles to the first; if any measurement is significantly different from the others, the tappet is tapered or oval (as applicable) and must be renewed. If the necessary equipment is available, measure the inside diameter of the corresponding cylinder head bore. Compare the measurements obtained to those given in the Specifications Section of this Chapter; if the tappets or the cylinder head bores are excessively worn, new tappets and/or a new cylinder head will be required.

9 If the engine's valve components have sounded noisy, particularly if the noise persists after initial start-up from cold, there is reason to suspect a faulty hydraulic tappet. Only a good mechanic experienced in these engines can tell whether the noise level is typical, or if renewal of one or more of the tappets is warranted. If faulty tappets are diagnosed, and the engine's service history is unknown, it is always worth trying the effect of renewing the engine oil and filter (see Chapter 1), using *only* good-quality engine oil of the recommended viscosity and specification, before going to the expense of renewing any of the tappets - refer also to the advice in Section 1 of this Chapter.

10 Visually examine the camshaft lobes for score marks, pitting, galling (wear due to rubbing) and evidence of overheating (blue, discoloured areas). Look for flaking away of the hardened surface layer of each lobe (see illustration). If any such signs are evident, renew the component concerned.

11 Examine the camshaft bearing journals and the cylinder head bearing surfaces for signs of obvious wear or pitting. If any such signs are evident, renew the component concerned.

12 Using a micrometer, measure the diameter of each journal at several points (see illustration). If the diameter of any one journal is less than the specified value, renew the camshaft.

13 To check the bearing journal running clearance, remove the hydraulic tappets, use a suitable solvent and a clean lint-free rag to clean carefully all bearing surfaces, then refit the camshafts and bearing caps with a strand of Plastigage across each journal (see illustration). Tighten the bearing cap bolts to the specified torque wrench setting (do not rotate the camshafts), then remove the bearing caps and use the scale provided to measure the width of the compressed strands (see illustration). Scrape off the Plastigage with your fingernail or the edge of a credit card - don't scratch or nick the journals or bearing caps.

14 If the running clearance of any bearing is

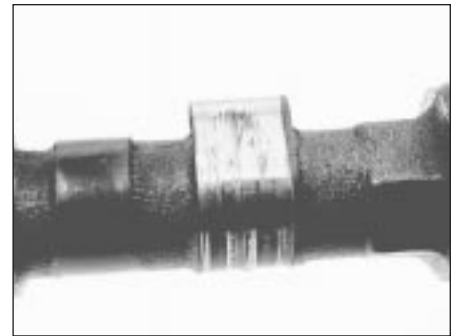

13.10 Check the cam lobes for pitting, wear and score marks - if scoring is excessive, as is the case here, renew the camshaft

found to be worn to beyond the specified service limits, fit a new camshaft and repeat the check; if the clearance is still excessive, the cylinder head must be renewed.

15 To check camshaft endfloat, remove the hydraulic tappets, clean the bearing surfaces carefully, and refit the camshafts and bearing caps. Tighten the bearing cap bolts to the specified torque wrench setting, then measure the endfloat using a DTI (Dial Test Indicator, or dial gauge) mounted on the cylinder head so that its tip bears on the camshaft right-hand end.

16 Tap the camshaft fully towards the gauge, zero the gauge, then tap the camshaft fully

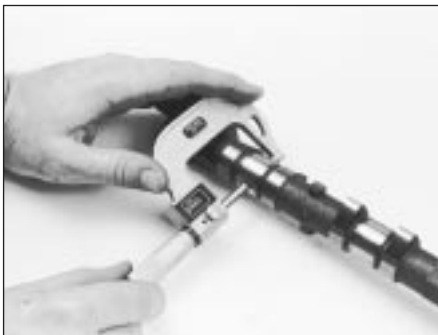

13.12 Measure each journal diameter with a micrometer - if any journal measures less than the specified limit, renew the camshaft



13.13A Lay a strip of Plastigage on each camshaft journal



13.13B Compare the width of the crushed Plastigage to the scale on the envelope to determine the running clearance



13.17 Oil liberally when refitting hydraulic tappets



13.18A Apply engine assembly lubricant or molybdenum disulphide-based grease to the cam lobes and journals before refitting a camshaft



13.18B Use camshaft position sensor lobe to identify inlet camshaft on refitting - locate camshafts as described in text



13.19 Apply sealant to mating surface of camshaft right-hand bearing caps

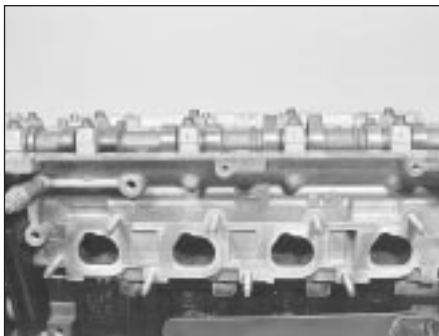

13.20 Etched marks on camshaft bearing caps must be arranged as shown, and face outwards

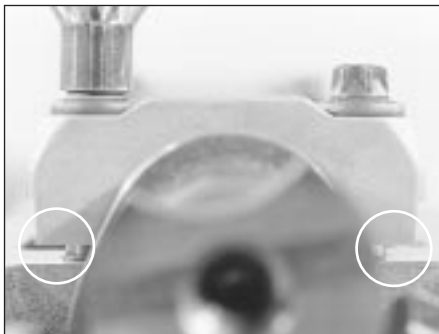

13.21A Keep caps square to cylinder head at all times when tightening down

away from the gauge, and note the gauge reading. If the endfloat measured is found to be at or beyond the specified service limit, fit a new camshaft and repeat the check; if the clearance is still excessive, the cylinder head must be renewed.

Refitting

17 On reassembly, liberally oil the cylinder head hydraulic tappet bores and the tappets (see illustration). Note that if new tappets are being fitted, they must be charged with clean engine oil before installation. Carefully refit the tappets to the cylinder head, ensuring that each tappet is refitted to its original bore, and is the correct way up. Some care will be required to enter the tappets squarely into their bores.

18 Liberally oil the camshaft bearings and lobes (see illustration). Ensuring that each camshaft is in its original location, refit the camshafts, locating each so that the slot in its left-hand end is approximately parallel to, and just above, the cylinder head mating surface (see illustration).

19 Ensure that the locating dowels are pressed firmly into their recesses, and check that all mating surfaces are completely clean, unmarked and free from oil. Apply a thin film of suitable sealant (Ford recommend Loctite 518) to the mating surfaces of each

camshaft's right-hand bearing cap (see illustration). Referring to paragraph 6 of Section 12, some owners may wish to fit the new camshaft oil seals at this stage.

20 All camshaft bearing caps have a single-digit identifying number etched on them (see illustration). The exhaust camshaft's bearing caps are numbered in sequence 0 (right-hand cap) to 4 (left-hand cap), the inlet's 5 (right-hand cap) to 9 (left-hand cap); see illustration 13.21B for details. Each cap is to be fitted so that its numbered side faces outwards, to the front (exhaust) or to the rear (inlet).

21 Ensuring that each cap is kept square to the cylinder head as it is tightened down, and working in the sequence shown, tighten the camshaft bearing cap bolts slowly and by one turn at a time, until each cap touches the cylinder head (see illustrations). Next, go round again in the same sequence, tightening the bolts to the first stage torque wrench setting specified, then once more, tightening them to the second stage setting. Work only as described, to impose gradually and evenly the pressure of the valve springs on the caps. Fit the camshaft aligning tool; it should slip into place as described in paragraph 10 of Section 10 (see illustration).

22 Wipe off all surplus sealant, so that none is left to find its way into any oilways. Follow the sealant manufacturer's instructions as to the time needed for curing; usually, at least an hour must be allowed between application of the sealant and starting the engine.

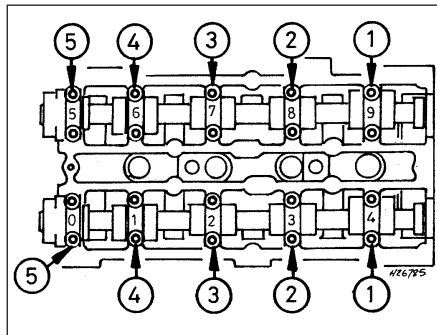

13.21B Camshaft bearing cap tightening sequence

Note: View from front of vehicle - locate bearing caps according to etched numbers, aligned as described in text



13.21C Fit camshaft aligning tool to set TDC position . . .

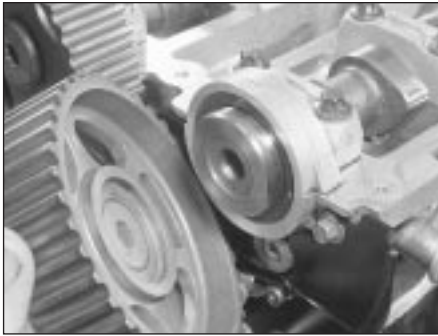

13.24 . . . while camshaft toothed pulleys are refitted

23 If using Ford's recommended procedure, fit new oil seals to the camshafts as described in paragraph 5 of Section 12.

24 Using the marks and notes made on dismantling to ensure that each is refitted to its original camshaft, refit the toothed pulleys to the camshafts, tightening the retaining bolts loosely (see illustration). Slip the timing belt back onto the pulleys (refer to paragraph 21 of Section 10) and tighten the bolts securely - use the forked holding tool described in paragraph 18 of Section 10.

25 The remainder of the reassembly procedure, including checking the camshaft alignment (valve timing) and setting the timing belt tension, is as described in paragraphs 17 to 27 of Section 10.

14 Cylinder head - removal and refitting



Removal

Note: The following text assumes that the cylinder head will be removed with both inlet and exhaust manifolds attached; this simplifies the procedure, but makes it a bulky and heavy assembly to handle - an engine hoist will be required, to prevent the risk of injury, and to prevent damage to any delicate components as the assembly is removed and refitted. If it is wished first to remove the manifolds, proceed as described in Sections 6 and 7 of this Chapter; amend the following procedure accordingly.

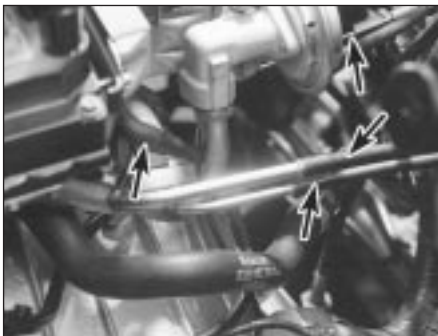

14.9 Disconnect vacuum hoses (arrowed) as described in text



14.8A Release wire clip to unplug engine wiring loom connector from inlet manifold

1 Relieve the fuel system pressure (see Chapter 4).

2 With the vehicle parked on firm level ground, open the bonnet and disconnect the battery negative (earth) lead - see Chapter 5, Section 1.

3 Whenever you disconnect any vacuum lines, coolant and emissions hoses, wiring loom connectors, earth straps and fuel lines as part of the following procedure, always label them clearly, so that they can be correctly reassembled.

HAYNES HINT Masking tape and/or a touch-up paint applicator work well for marking items. Take instant photos, or sketch the locations of components and brackets.

4 Unplugging the two electrical connectors, disconnecting the vacuum hose (where fitted) and disconnecting the crankcase breather hose from the cylinder head cover, remove the complete air cleaner assembly with the air mass meter, the resonator and the plenum chamber (see Chapter 4).

5 Equalise the pressure in the fuel tank by removing the filler cap, then undo the fuel feed and return lines connecting the engine to the chassis (see Chapter 4). Plug or cap all open fittings.

6 Disconnect the accelerator cable from the throttle linkage as described in Chapter 4 -

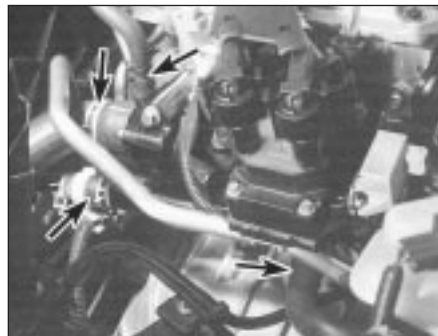

14.13 Disconnect all coolant hoses (arrowed) from thermostat housing

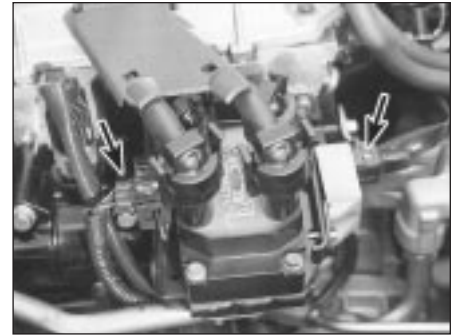

14.8B Unplug connectors (arrowed) to disconnect ignition coil wiring

where fitted, disconnect also the cruise control actuator cable (see Chapter 12). Secure the cable(s) clear of the engine/transmission.

7 Unbolt the power steering high-pressure pipe from the cylinder head rear support plate/engine lifting eye, and from the front support plate/pump bracket. Releasing its wire clip, unplug the power steering pressure switch electrical connector, then unbolt the earth lead from the cylinder head rear support plate/engine lifting eye.

8 Remove the three screws securing the wiring "rail" to the rear of the manifold. Releasing its wire clip, unplug the large electrical connector (next to the fuel pressure regulator) to disconnect the engine wiring from the main loom (see illustration). Unplug the electrical connectors on each side of the ignition coil, and the single connector from beneath the front of the thermostat housing, to disconnect the coil and coolant temperature gauge sender wiring (see illustration).

9 Marking or labelling them as they are unplugged, disconnect the vacuum hoses as follows:

- (a) One from the rear of the throttle housing (only the one hose - there is no need to disconnect the second hose running to the fuel pressure regulator).
- (b) One from the union on the inlet manifold's left-hand end (see illustration).
- (c) The braking system vacuum servo unit hose (see Chapter 9 for details).
- (d) Disconnect all vacuum hoses from the Exhaust Gas Recirculation system components - one from the EGR valve and two from the EGR pipe. (Note that these last two are of different sizes, as are their pipe stubs, so that they can only be connected the correct way round.)

10 Unbolt both parts of the exhaust manifold heat shield; unclip the coolant hose to allow the upper part to be withdrawn. Either remove the dipstick and tube, or swing them out of the way.

11 Unscrew the single bolt securing the pulse-air filter housing to the engine/transmission front mounting bracket, then disconnect its vacuum hose.

12 Drain the cooling system (see Chapter 1).

13 Disconnect all coolant hoses from the thermostat housing (see illustration).



14.17 Unbolt auxiliary drivebelt idler pulley



14.18A Remove cylinder head front . . .



14.18B . . . and rear support plates

14 Unscrew the two nuts to disconnect the exhaust system front downpipe from the manifold (Chapter 4); disconnect the oxygen sensor wiring, so that it is not strained by the weight of the exhaust system.

15 Remove the auxiliary drivebelt (see Chapter 1).

16 Support the weight of the engine/transmission using a trolley jack, with a wooden spacer to prevent damage to the sump.

17 Unscrew the six nuts securing the engine/transmission right-hand mounting bracket, then withdraw the bracket. Unbolt the auxiliary drivebelt's idler pulley (see illustration).

18 Unbolt the cylinder head front and rear support plates (see illustrations).

19 Remove the timing belt and both camshafts (see Sections 10 and 13); if the cylinder head is to be dismantled, withdraw the hydraulic tappets.

20 Remove the timing belt inner shield (see Section 9).

21 Working in the *reverse* of the sequence shown in illustration 14.32C, slacken the ten cylinder head bolts progressively and by one turn at a time; a Torx key (TX 55 size) will be required. Remove each bolt in turn, and ensure that new replacements are obtained for reassembly; these bolts are subjected to severe stresses and so must be renewed, regardless of their apparent condition, whenever they are disturbed.



14.22 Using an engine hoist to lift off the cylinder head complete with manifolds

22 Lift the cylinder head away; use assistance if possible, as it is a heavy assembly (see illustration). Remove the gasket, noting the two dowels, and discard it.

Refitting

23 The mating faces of the cylinder head and cylinder block must be perfectly clean before refitting the head. Use a hard plastic or wood scraper to remove all traces of gasket and carbon; also clean the piston crowns. Take particular care, as the soft aluminium alloy is easily damaged. Also, make sure that the carbon is not allowed to enter the oil and water passages - this is particularly important for the lubrication system, as carbon could block the oil supply to any of the engine's components. Using adhesive tape and paper, seal the water, oil and bolt holes in the cylinder block. Clean all the pistons in the same way.

HAYNES HINT

To prevent carbon entering the gap between the pistons and bores, smear a little grease in the gap. After cleaning each piston, use a small brush to remove all traces of grease and carbon from the gap, then wipe away the remainder with a clean rag.

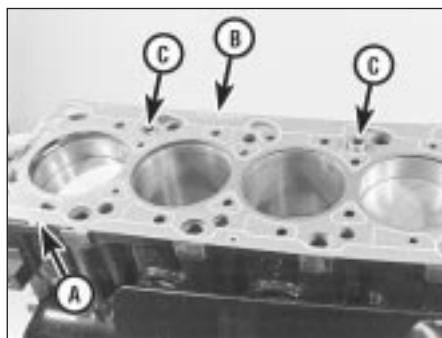

14.27 Ensuring protruding tooth (or teeth) "A" are at front and marking "B" is upwards, locate new cylinder head gasket on dowels "C"

24 Check the mating surfaces of the cylinder block and the cylinder head for nicks, deep scratches and other damage. If slight, they may be removed carefully with a file, but if excessive, machining may be the only alternative to renewal.

25 If warpage of the cylinder head gasket surface is suspected, use a straight edge to check it for distortion. Refer to Part B of this Chapter, Section 7, if necessary.

26 Wipe clean the mating surfaces of the cylinder head and cylinder block. Check that the two locating dowels are in position in the cylinder block, and that all cylinder head bolt holes are free from oil.

27 Position a new gasket over the dowels on the cylinder block surface, so that the "TOP/OBEN" mark is uppermost, and the tooth (or teeth, according to engine size) protruding from one edge point to the front of the vehicle (see illustration).

28 Temporarily refit the crankshaft pulley, and rotate the crankshaft anti-clockwise so that No 1 cylinder's piston is lowered to approximately 20 mm before TDC, thus avoiding any risk of valve/piston contact and damage during reassembly.

29 As the cylinder head is such a heavy and awkward assembly to refit with manifolds, it is helpful to make up a pair of guide studs from two 10 mm (thread size) studs approximately 90 mm long, with a screwdriver slot cut in one end - two old cylinder head bolts with their heads cut off would make a good starting point. Screw these guide studs, screwdriver slot upwards to permit removal, into the bolt holes at diagonally-opposite corners of the cylinder block surface (or into those where the locating dowels are fitted, as shown); ensure that approximately 70 mm of stud protrudes above the gasket.

30 Refit the cylinder head, sliding it down the guide studs (if used) and locating it on the dowels (see illustration). Unscrew the guide studs (if used) when the head is in place.

31 Fit the new cylinder head bolts dry (*do not oil* their threads); carefully enter each into its hole and screw it in, by hand only, until finger-tight.

32 Working progressively and in the sequence shown, use first a torque wrench,

then an ordinary socket extension bar and an angle gauge, to tighten the cylinder head bolts in the stages given in the Specifications Section of this Chapter (see illustrations). **Note:** Once tightened correctly, following this procedure, the cylinder head bolts do not require check-tightening, and must **not** be re-torqued.

33 Refit the hydraulic tappets (if removed), the camshafts, their oil seals and pulleys (see Sections 10, 11, 12 and 13, as appropriate). Temporarily refit the crankshaft pulley, and rotate the crankshaft clockwise to return the pulley notches to the position described in paragraph 8 of Section 10.

34 Refit the timing belt and covers, checking the camshaft alignment (valve timing) and setting the timing belt tension, as described in Section 10.

35 The remainder of reassembly is the reverse of the removal procedure, noting the following points:

- (a) Tighten all fasteners to the torque wrench settings specified.
- (b) When reassembling the engine/transmission right-hand mounting, renew the self-locking nuts, and do not allow the mounting to twist as the middle two of the bracket's six nuts are tightened.
- (c) Refill the cooling system, and top-up the engine oil.
- (d) Check all disturbed joints for signs of oil or coolant leakage, once the engine has been restarted and warmed-up to normal operating temperature.

15 Sump - removal and refitting

Removal

Note: To carry out this task with the engine/transmission installed in the vehicle requires the assistance of at least one person, plus the equipment necessary to raise and support the front of the vehicle (high enough that the sump can be withdrawn from underneath), and to lift and support the complete engine/transmission unit 2 to



14.32B . . . and to third stage using angle gauge



14.30 Refitting cylinder head - note fabricated guide studs (arrowed)

3 inches from its mountings while the vehicle is raised. Precise details of the procedure will depend on the equipment available - the following is typical.

The full procedure outlined below must be followed, so that the mating surfaces can be cleaned and prepared to achieve an oil-tight joint on reassembly, and so that the sump can be aligned correctly; depending on your skill and experience, and the tools and facilities available, it may be that this task can be carried out only with the engine removed from the vehicle.

Note that the sump gasket must be renewed whenever it is disturbed.

1 With the vehicle parked on firm level ground, open the bonnet and disconnect the battery negative (earth) lead - see Chapter 5, Section 1.

2 Drain the engine oil, then clean and refit the engine oil drain plug, tightening it to the specified torque wrench setting. Although not strictly necessary as part of the dismantling procedure, owners are advised to remove and discard the oil filter, so that it can be renewed with the oil (see Chapter 1).

3 Drain the cooling system (see Chapter 1).

4 Disconnect the radiator bottom hose from the radiator union and from the (heater) coolant pipe. Unbolt the coolant pipe from the sump; if they will prevent sump removal, disconnect or release the coolant hoses from the oil cooler unions (where fitted).

5 Unscrew the two bolts securing the power

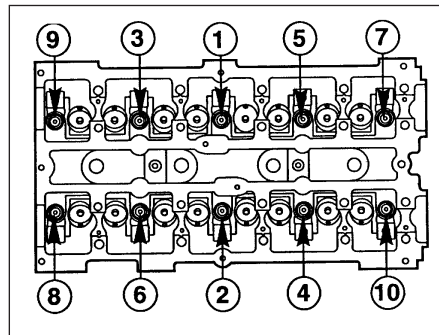

14.32C Cylinder head bolt tightening sequence

Note: View from rear of vehicle



14.32A Tightening cylinder head bolts (to first and second stages) using torque wrench . . .

steering system pipes to the right-hand side of the subframe.

6 Unplug the electrical connector(s) to disconnect the oxygen sensor and, where fitted, the oil level sensor wiring - unclip the connectors to release the wiring where necessary.

7 Where the vehicle is fitted with automatic transmission, trace the fluid cooler lines from the transmission to the radiator, and release them from any clips etc, so that they have as much movement as possible.

8 Remove the auxiliary drivebelt cover (see Chapter 1).

9 Unscrew the nuts to disconnect the exhaust system front downpipe from the manifold, then either unhook all the system's rubber mountings and withdraw the complete exhaust system from under the vehicle, or remove only the downpipe/catalytic converter (see Chapter 4 for details).

10 Unscrew the sump-to-transmission bolts, also any securing the engine/transmission lower adaptor plate.

11 Unplugging the two electrical connectors, disconnecting the vacuum hose (where fitted) and disconnecting the crankcase breather hose from the cylinder head cover, remove the complete air cleaner assembly with the air mass meter, the resonator and the plenum chamber (see Chapter 4).

12 Take the weight of the engine/transmission unit using the lifting eyes provided on the cylinder head; bolt on



15.12 Equipment must be available to raise and support engine/transmission unit while vehicle is raised, to allow sump removal



15.17 Ensure gasket is located correctly in sump groove



15.18 Engine/transmission lower adaptor plate (arrowed) must be refitted with sump



15.19A Apply sealant (arrowed) as directed when refitting sump

additional lifting eyes where required (see illustration). Remove completely the engine/transmission front mounting, unscrew the rear mounting's centre bolt, and unbolt the left-hand mounting from the body. Unscrew the six nuts securing the right-hand mounting bracket, and withdraw the bracket.

13 Being careful to watch the wiring, coolant hoses, fluid cooler pipes or gearchange linkage and transmission support rods (where appropriate), and the radiator electric cooling fan, to ensure that nothing is trapped, stretched or damaged, lift the engine/transmission unit by 2 to 3 inches and support it securely.

14 Progressively unscrew the sump retaining bolts. Break the joint by striking the sump with the palm of the hand, then lower the sump and withdraw it with the engine/transmission lower adaptor plate; note the presence of any shims between the sump and transmission.

15 Remove and discard the sump gasket; this must be renewed as a matter of course whenever it is disturbed.

16 While the sump is removed, take the opportunity to remove the oil pump pick-up/strainer pipe and to clean it (see Section 16).

Refitting

17 On reassembly, thoroughly clean and degrease the mating surfaces of the cylinder block/crankcase and sump, then use a clean

rag to wipe out the sump and the engine's interior. If the oil pump pick-up/strainer pipe was removed, fit a new gasket and refit the pipe, tightening its screws to the specified torque wrench setting. Fit the new gasket to the sump mating surface so that the gasket fits into the sump groove (see illustration).

18 If the sump is being refitted with the engine/transmission still connected and in the vehicle, proceed as follows:

- (a) Check that the mating surfaces of the sump, the cylinder block/crankcase and the transmission are absolutely clean and flat. Any shims found on removal of the sump must be refitted in their original locations.
- (b) Apply a thin film of suitable sealant (Ford recommend Hylosil 102) to the junctions of the cylinder block/crankcase with the oil pump and the crankshaft left-hand oil seal carrier. Without delay - the sump bolts must be fully tightened within 10 to 20 minutes of applying the sealant - offer up the sump and engine/transmission lower adaptor plate, and refit the bolts, tightening them lightly at first (see illustration).
- (c) Ensuring that the engine/transmission lower adaptor plate is correctly located, firmly press the sump against the transmission, and tighten the transmission-to-sump (ie, engine) bolts to the specified torque wrench setting.

(d) Without disturbing the position of the sump, and working in a diagonal sequence from the centre outwards, tighten the sump bolts to the specified torque wrench setting.

(e) Proceed to paragraph 20.

19 If the sump is being refitted with the engine and transmission separated (in or out of the vehicle), proceed as follows:

- (a) Apply a thin film of suitable sealant (Ford recommend Hylosil 102) to the junctions of the cylinder block/crankcase with the oil pump and the crankshaft left-hand oil seal carrier (see illustration). Without delay - the sump bolts must be fully tightened within 10 to 20 minutes of applying the sealant - offer up the sump to the cylinder block/crankcase, and insert the sump bolts, tightening them lightly at first.
- (b) Using a suitable straight edge to check alignment across the flat-machined faces of each, move the sump as necessary so that its left-hand face - including any shims found on removal - is flush with that of the cylinder block/crankcase (see illustration). Without disturbing the position of the sump, and working in a diagonal sequence from the centre outwards, tighten the sump bolts to the specified torque wrench setting.
- (c) Check again that both faces are flush before proceeding; if necessary, unbolt the sump again, clean the mating surfaces, and repeat the full procedure to ensure that the sump is correctly aligned.
- (d) If it is not possible to achieve exact alignment by moving the sump, shims are available in thicknesses of 0.25 mm (colour-coded yellow) or 0.50 mm (colour-coded black) to eliminate the discrepancy (see illustration).

20 The remainder of reassembly is the reverse of the removal procedure, noting the following points.

- (a) Tighten all fasteners to the torque wrench settings specified.
- (b) Always renew any self-locking nuts disturbed on removal.
- (c) Lower the engine/transmission unit into place, and reassemble the rear, left-hand



15.19B Checking alignment of sump with cylinder block/crankcase

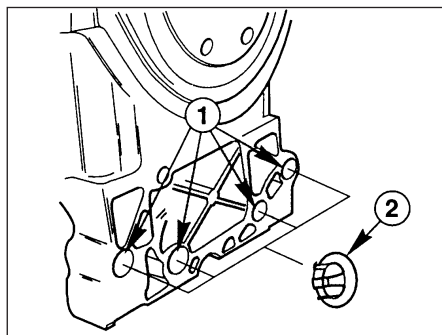

15.19C Sump-to-cylinder block/crankcase alignment shims

1 Fitting points on sump 2 Shim

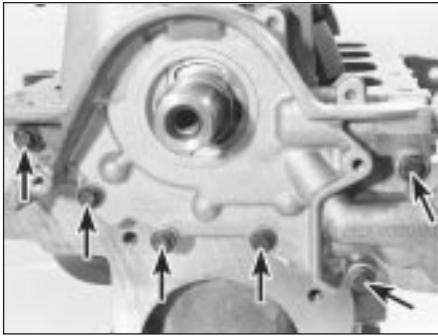

16.5 Unscrew bolts (arrowed) to remove oil pump

and right-hand mountings. Do not yet release the hoist; the weight of the engine/transmission unit must not be taken by the mountings until all are correctly aligned.

- (d) Fitting the Ford service tool in place of the front mounting, tighten the engine/transmission mounting fasteners to their specified torque wrench settings, and in the sequence described in Part B of this Chapter, Section 4, paragraphs 49 and 50.
- (e) Refill the cooling system (see Chapter 1).
- (f) Refill the engine with oil, remembering that you are advised to fit a new filter (see Chapter 1).
- (g) Check for signs of oil or coolant leaks once the engine has been restarted and warmed-up to normal operating temperature.

16 Oil pump - removal, inspection and refitting



Removal

Note: While this task is theoretically possible when the engine is in place in the vehicle, in practice, it requires so much preliminary dismantling, and is so difficult to carry out due to the restricted access, that owners are advised to remove the engine from the vehicle first. Note, however, that the oil pump



16.6 Withdrawing oil pump inner rotor

pressure relief valve can be removed with the engine in situ - see paragraph 8.

In addition to the new pump gasket and other replacement parts required, read through Section 15, and ensure that the necessary tools and facilities are available.

- 1 Remove the timing belt (see Section 10).
- 2 Withdraw the crankshaft toothed pulley and the thrustwasher behind it, noting which way round the thrustwasher is fitted (see Section 11).
- 3 Remove the sump (see Section 15).
- 4 Undo the screws securing the oil pump pick-up/strainer pipe to the pump, then unscrew the nut and withdraw the oil pump pick-up/strainer pipe. Discard the gasket.
- 5 Unbolt the pump from the cylinder block/crankcase (see illustration). Withdraw and discard the gasket, and remove the crankshaft right-hand oil seal. Thoroughly clean and degrease all components, particularly the mating surfaces of the pump, the sump, and the cylinder block/crankcase.

Inspection

- 6 Unscrew the Torx screws, and remove the pump cover plate; noting any identification marks on the rotors, withdraw the rotors (see illustration).
- 7 Inspect the rotors for obvious signs of wear or damage, and renew if necessary; if either rotor, the pump body, or its cover plate are scored or damaged, the complete oil pump assembly must be renewed.
- 8 The oil pressure relief valve can be



16.9A Unscrew threaded plug - seen through right-hand wheel arch . . .

dismantled, if required, without disturbing the pump. With the vehicle parked on firm level ground, apply the handbrake securely and raise its front end, supporting it securely on axle stands. Remove the front right-hand roadwheel and auxiliary drivebelt cover (see Chapter 1) to provide access to the valve.

- 9 Unscrew the threaded plug, and recover the valve spring and plunger (see illustrations). If the plug's sealing O-ring is worn or damaged, a new one must be obtained, to be fitted on reassembly.
- 10 Reassembly is the reverse of the dismantling procedure; ensure the spring and valve are refitted the correct way round, and tighten the threaded plug securely.

Refitting

- 11 The oil pump must be primed on installation, by pouring clean engine oil into it, and rotating its inner rotor a few turns.
- 12 Using grease to stick the new gasket in place on the cylinder block/crankcase, and rotating the pump's inner rotor to align with the flats on the crankshaft, refit the pump and insert the bolts, tightening them lightly at first (see illustration).
- 13 Using a suitable straight edge and feeler gauges, check that the pump is both centred exactly around the crankshaft, and aligned squarely so that its (sump) mating surface is exactly the same amount - between 0.3 and 0.8 mm - below that of the cylinder block/crankcase on each side of the crankshaft (see illustration). Being careful not to disturb



16.9B . . . to withdraw oil pressure relief valve spring and plunger



16.12 Use new gasket when refitting oil pump



16.13 Check the oil pump is positioned correctly

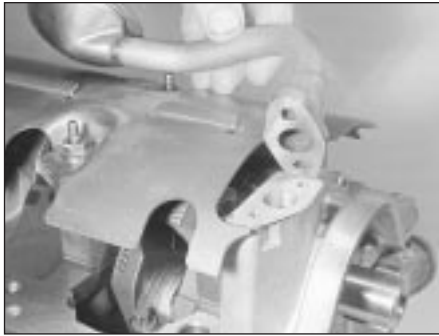

16.16 Use new gasket when refitting oil pick-up pipe to pump

the gasket, move the pump into the correct position, and tighten its bolts to the specified torque wrench setting.

14 Check that the pump is correctly located; if necessary, unbolt it again, and repeat the full procedure to ensure that the pump is correctly aligned.

15 Fit a new crankshaft right-hand oil seal (see Section 20).

16 Using grease to stick the gasket in place on the pump, refit the pick-up/strainer pipe, tightening its screws and nut to their specified torque wrench settings (see illustration).

17 The remainder of reassembly is the reverse of the removal procedure, referring to the relevant text for details where required.

17 Oil cooler - removal and refitting

1 Drain the cooling system (see Chapter 1). Disconnect the coolant hoses from the oil cooler.

2 Unscrew the oil filter (see Chapter 1) - catch any escaping oil in a drip tray.

3 Unscrew the filter adaptor from the oil pump, and withdraw the oil cooler; note how its unions are aligned, and be prepared for oil loss from the cooler.

4 Refitting is the reverse of the removal procedure, noting the following points:



19.1 Oil pressure warning light switch (arrowed) is screwed into rear of cylinder block, above right-hand driveshaft support bearing



18.3 Remove screws (arrowed) to remove oil level sensor cover . . .

(a) Renew all O-rings and seals disturbed on removal.

(b) Align the cooler's unions as noted on removal, and tighten the adaptor to the specified torque wrench setting.

(c) Refill the cooling system (see Chapter 1).

(d) Refit the oil filter, then check the engine oil level, and top-up as necessary (see Chapter 1).

(e) Check for signs of oil or coolant leaks once the engine has been restarted and warmed-up to normal operating temperature.

18 Oil level sensor - removal and refitting

1 With the vehicle parked on firm level ground, open the bonnet and disconnect the battery negative (earth) lead - see Chapter 5, Section 1.

2 Raise the front of the vehicle, and support it securely on axle stands.

3 Undo the two screws, and remove the sensor's cover from the front of the sump (see illustration).

4 Unplug the wiring from the sensor (see illustration). Where necessary, unplug the electrical connector to disconnect the sensor wiring, and unclip the connector to release the wiring from the vehicle.

5 Unscrew the sensor, and quickly plug the sump aperture to minimise oil loss; note the sensor's seal.



20.2 Driving out crankshaft right-hand oil seal



18.4 . . . disconnecting wiring from sensor

6 Refitting is the reverse of the removal procedure; renew the sensor's seal if it is worn or damaged, and tighten the sensor to the specified torque wrench setting. Check the engine oil level, and top-up as necessary (see Chapter 1) - check for signs of oil leaks once the engine has been restarted and warmed-up to normal operating temperature.

19 Oil pressure warning light switch - removal and refitting

1 The switch is screwed into the rear of the cylinder block, above the right-hand driveshaft's support bearing (see illustration).

2 With the vehicle parked on firm level ground, open the bonnet and disconnect the battery negative (earth) lead - see Chapter 5, Section 1.

3 Raise the front of the vehicle, and support it securely on axle stands.

4 Unplug the wiring from the switch, and unscrew it; be prepared for some oil loss.

5 Refitting is the reverse of the removal procedure; apply a thin smear of suitable sealant to the switch threads, and tighten it to the specified torque wrench setting. Check the engine oil level, and top-up as necessary (see Chapter 1). Check for signs of oil leaks once the engine has been restarted and warmed-up to normal operating temperature.

20 Crankshaft oil seals - renewal

Note: Don't try to prise these seals out without removing the oil pump or seal carrier - the seals are too soft, and the amount of space available is too small, for this to be possible without considerable risk of damage to the seal housing and/or the crankshaft journal. Follow exactly the procedure given below.

Right-hand seal

1 Remove the oil pump (see Section 16).
2 Drive the oil seal out of the pump from behind (see illustration).



20.5 Socket of correct size can be used to replace Ford service tool, drawing new seal into place as described

3 Clean the seal housing and crankshaft, polishing off any burrs or raised edges, which may have caused the seal to fail in the first place.

4 Refit the oil pump (see Section 16). Grease the lips and periphery of the new seal, to ease installation.

5 To fit a new seal, Ford recommend the use of their service tool 21-093A, with the crankshaft pulley bolt, to draw the seal into place; an alternative can be arranged using a socket of suitable size, with a washer to match the crankshaft pulley bolt (see illustration).

6 If such tools are not available, press the seal squarely into place by hand; tap it in until it is flush with the pump housing, using a soft-faced mallet and a socket with an outside diameter only slightly smaller than the seal's (see illustration). This approach requires great care, to ensure that the seal is fitted squarely, without distortion or damage.

7 Wash off any traces of oil. The remainder of reassembly is the reverse of the removal procedure, referring to the relevant text for details where required. Check for signs of oil leakage when the engine is restarted.

Left-hand seal

8 Remove the transmission (see the relevant Part of Chapter 7).

9 Where appropriate, remove the clutch (Chapter 8).

10 Unbolt the flywheel/driveplate (see Section 21).



20.15 Use new gasket when refitting left-hand oil seal carrier



20.6 If seal is tapped into place as shown, exercise great care to prevent seal from being damaged or distorted

11 Remove the sump (see Section 15).

12 Unbolt the oil seal carrier (see illustration). Remove and discard its gasket.

13 Supporting the carrier evenly on wooden blocks, drive the oil seal out of the carrier from behind (see illustration).

14 Clean the seal housing and crankshaft, polishing off any burrs or raised edges, which may have caused the seal to fail in the first place. Clean also the mating surfaces of the cylinder block/crankcase and carrier, using a scraper to remove all traces of the old gasket - be careful not to scratch or damage the material of either - then use a suitable solvent to degrease them.

15 Use grease to stick the new gasket in place on the cylinder block/crankcase, then offer up the carrier (see illustration).

16 Using a suitable straight edge and feeler gauges, check that the carrier is both centred *exactly* around the crankshaft, and aligned squarely so that its (sump) mating surface is exactly the same amount - between 0.3 and 0.8 mm - below that of the cylinder block/crankcase on each side of the crankshaft. Being careful not to disturb the gasket, move the carrier into the correct position, and tighten its bolts to the specified torque wrench setting (see illustration).

17 Check that the carrier is correctly located; if necessary, unbolt it again, and repeat the full procedure to ensure that the carrier is correctly aligned.

18 Ford's recommended method of seal fitting is to use service tool 21-141, with two



20.16 Check the oil seal carrier is correctly positioned

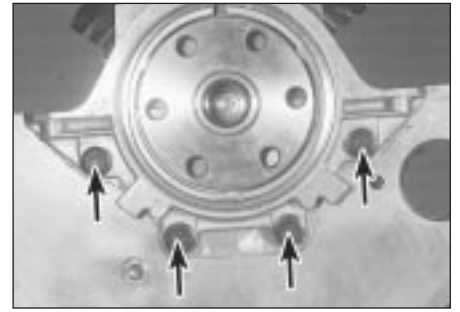

20.12 Unscrew bolts (arrowed) to remove crankshaft left-hand oil seal carrier . . .



20.13 . . . and ensure that carrier is properly supported when driving out used oil seal - note notches provided in carrier for drift

flywheel bolts to draw the seal into place. If this is not available, make up a guide from a thin sheet of plastic or similar, lubricate the lips of the new seal and the crankshaft shoulder with grease, then offer up the seal, with the guide feeding the seal's lips over the crankshaft shoulder (see illustration). Press the seal evenly into its housing by hand only, and use a soft-faced mallet gently to tap it into place until it is flush with the surrounding housing.

19 Wipe off any surplus oil or grease; the remainder of the reassembly procedure is the reverse of dismantling, referring to the relevant text for details where required. Check for signs of oil leakage when the engine is restarted.



20.18 Using guide made from thin sheet of plastic to slide oil seal lips over crankshaft shoulder

21 Flywheel/driveplate - removal, inspection and refitting



Removal

1 Remove the transmission (see the relevant Part of Chapter 7). Now is a good time to check components such as oil seals and renew them if necessary.

2 Where appropriate, remove the clutch (Chapter 8). Now is a good time to check or renew the clutch components and pilot bearing.

3 Use a centre-punch or paint to make alignment marks on the flywheel/driveplate and crankshaft, to ensure correct alignment during refitting.

4 Prevent the flywheel/driveplate from turning by locking the ring gear teeth, or by bolting a strap between the flywheel/driveplate and the cylinder block/crankcase. Slacken the bolts evenly until all are free.

5 Remove each bolt in turn, and ensure that new replacements are obtained for reassembly; these bolts are subjected to severe stresses, and so must be renewed, regardless of their apparent condition, whenever they are disturbed.

6 Noting the reinforcing plate (automatic transmission-equipped models only), withdraw the flywheel/driveplate; do not drop it - it is very heavy.

Inspection

7 Clean the flywheel/driveplate to remove grease and oil. Inspect the surface for cracks, rivet grooves, burned areas and score marks. Light scoring can be removed with emery cloth. Check for cracked and broken ring gear teeth. Lay the flywheel/driveplate on a flat surface, and use a straight edge to check for warpage.

8 Clean and inspect the mating surfaces of the flywheel/driveplate and the crankshaft. If the crankshaft left-hand seal is leaking, renew it (see Section 20) before refitting the flywheel/driveplate.

9 While the flywheel/driveplate is removed,



21.11 Note method used to lock flywheel/driveplate while (new) bolts are tightened

clean carefully its inboard (right-hand) face, particularly the recesses which serve as the reference points for the crankshaft speed/position sensor. Clean the sensor's tip, and check that the sensor is securely fastened.

Refitting

10 On refitting, ensure that the engine/transmission adaptor plate is in place (where necessary), then fit the flywheel/driveplate to the crankshaft so that all bolt holes align - it will fit only one way - check this using the marks made on removal. Do not forget the reinforcing plate (where fitted).

11 Lock the flywheel/driveplate by the method used on dismantling. Working in a diagonal sequence to tighten them evenly, and increasing to the final amount in two or three stages, tighten the new bolts to the specified torque wrench setting (see illustration).

12 The remainder of reassembly is the reverse of the removal procedure, referring to the relevant text for details where required.

22 Engine/transmission mountings - inspection and renewal



General

1 The engine/transmission mountings seldom require attention, but broken or deteriorated mountings should be renewed immediately, or the added strain placed on the driveline components may cause damage or wear.

2 While separate mountings may be removed and refitted individually, if more than one is disturbed at a time - such as if the

engine/transmission unit is removed from its mountings - they must be reassembled and their fasteners tightened in a strict sequence.

3 On reassembly, the weight of the engine/transmission unit must not be taken by the mountings until all are correctly aligned. Fitting the Ford service tool in place of the front mounting, tighten the engine/transmission mounting fasteners to their specified torque wrench settings, and in the sequence described in Part B of this Chapter, Section 4, paragraphs 49 and 50.

Inspection

4 During the check, the engine/transmission unit must be raised slightly, to remove its weight from the mountings.

5 Raise the front of the vehicle, and support it securely on axle stands. Position a jack under the sump, with a large block of wood between the jack head and the sump, then carefully raise the engine/transmission just enough to take the weight off the mountings.



Warning: DO NOT place any part of your body under the engine when it is supported only by a jack!

6 Check the mountings to see if the rubber is cracked, hardened or separated from the metal components. Sometimes the rubber will split right down the centre.

7 Check for relative movement between each mounting's brackets and the engine/transmission or body (use a large screwdriver or lever to attempt to move the mountings). If movement is noted, lower the engine and check-tighten the mounting fasteners.

Renewal

Front mounting

8 Unbolt the resonator support bracket from the engine compartment front crossmember, slacken the two clamp screws securing the

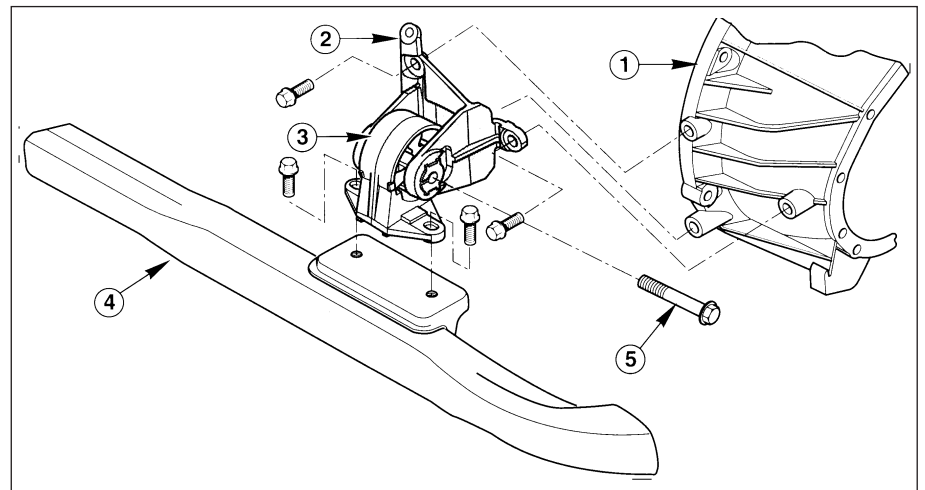

22.8 Engine/transmission front mounting - manual transmission shown, automatic equivalent similar

1 Transmission
2 Mounting bracket

3 Mounting

4 Front suspension subframe

5 Mounting centre bolt

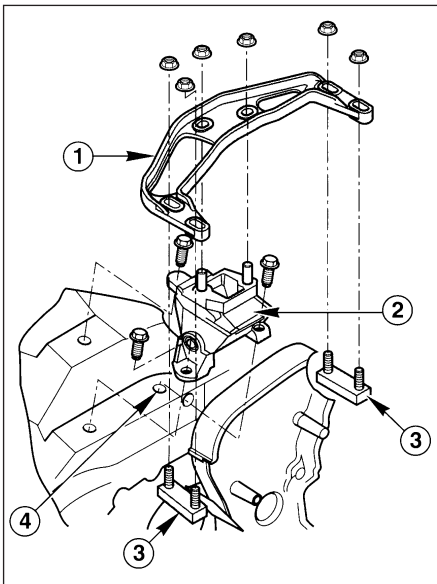

22.10 Engine/transmission right-hand mounting - standard type

- 1 Bracket
- 2 Mounting
- 3 Brackets bolted to cylinder block/crankcase
- 4 Vehicle body

resonator to the air mass meter and plenum chamber hoses, then swing the resonator up clear of the thermostat housing (see Chapter 4). Unbolt the pulse-air filter housing from the mounting bracket, then unfasten the

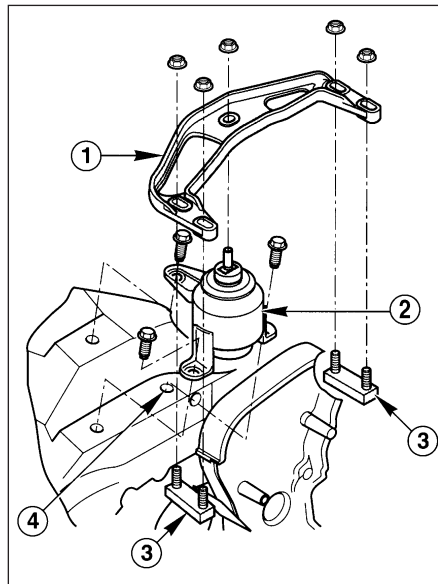

22.11 Engine/transmission right-hand mounting - hydraulic type (where fitted)

- 1 Bracket
- 2 Hydraulic mounting
- 3 Brackets bolted to cylinder block/crankcase
- 4 Vehicle body

bolts/nuts securing the mounting to the subframe, unscrew the centre bolt and withdraw the mounting; note the location of the wiring connector bracket. The mounting's bracket can be unbolted from the transmission if required (see illustration).

9 On refitting, ensure that the mounting-to-transmission bolts are securely tightened, then refit the mounting and wiring connector bracket. Tighten first the mounting-to-subframe bolts/nuts, noting that these are to be tightened in two stages to the final specified torque wrench setting. Finally tighten the mounting's centre bolt, again to the specified torque wrench setting.

Right-hand mounting

10 Unscrew the nuts and withdraw the bracket; note that these nuts are self-locking, and must therefore be renewed whenever

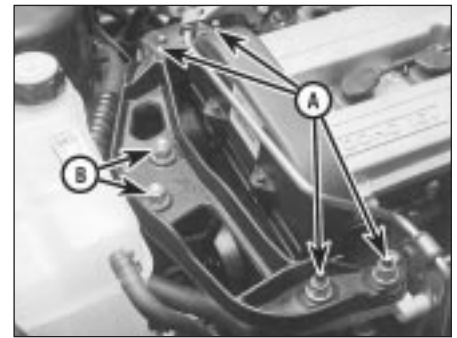

22.12 When reassembling engine/transmission right-hand mounting, tighten nuts "A" first, release lifting equipment, then tighten remaining nuts "B" - do not allow mounting to twist when doing so

they are disturbed. Unbolt the mounting from the body (see illustration).

11 Where hydraulic-type mountings are fitted - there are only five nuts securing the bracket, and the mounting is clearly identifiable from its shape - take care never to tilt these more than 5° from the vertical (see illustration).

12 On refitting, renew the self-locking nuts, and tighten all fasteners to the torque wrench settings specified. When tightening the nuts, tighten first the four bracket-to-engine nuts, then release the hoist or jack to allow the engine/transmission's weight to rest on the mounting. Do not allow the mounting to twist as the last two of the nuts are tightened (see illustration).

Left-hand mounting

13 Unplugging the two electrical connectors, disconnecting the vacuum hose (where fitted) and disconnecting the crankcase breather hose from the cylinder head cover, remove the complete air cleaner assembly with the air mass meter, the resonator and the plenum chamber (see Chapter 4).

14 Unscrew the three nuts to release the mounting from the transmission, then unbolt it from the body (see illustration). Note that

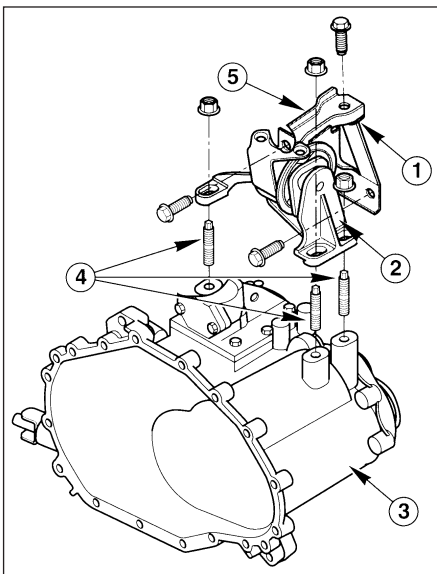

22.14 Engine/transmission left-hand mounting - manual transmission shown, automatic equivalent similar

- 1 Mounting bracket
- 2 Mounting
- 3 Transmission
- 4 Studs
- 5 Fastening plate - where fitted

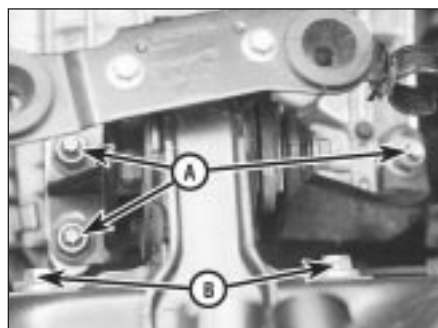

22.15 Engine/transmission left-hand mounting is secured by self-locking nuts "A" to transmission, by bolts "B" to body



22.16 Where vehicle is fitted with automatic transmission, additional damper may be fastened to underside of engine/transmission rear mounting, as shown

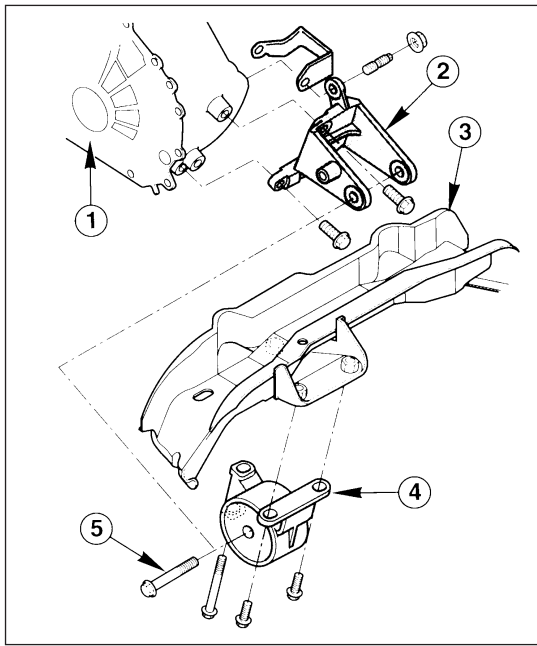

22.17A Engine/transmission rear mounting - manual transmission type

- | | |
|-----------------------------|------------------------|
| 1 Transmission | 4 Mounting |
| 2 Mounting bracket | 5 Mounting centre bolt |
| 3 Front suspension subframe | |

the nuts are self-locking, and must therefore be renewed whenever they are disturbed. Unscrew the centre bolt to dismantle the mounting, if necessary to renew components. **15** On refitting, renew the self-locking nuts, and do not allow the mounting to twist as the nuts are tightened (**see illustration**). Tighten all fasteners to the specified torque wrench settings.

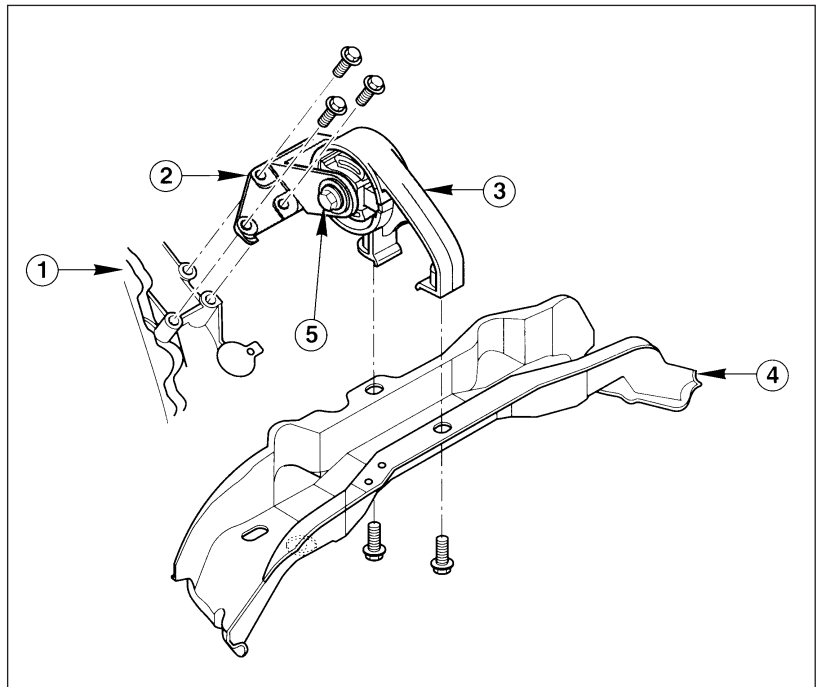

22.17B Engine/transmission rear mounting - automatic transmission type

- | | | |
|--------------------|-----------------------------|------------------------|
| 1 Transmission | 3 Mounting | 5 Mounting centre bolt |
| 2 Mounting bracket | 4 Front suspension subframe | |

Rear mounting

16 Where the vehicle is fitted with automatic transmission, a separate damper may be fitted beneath the subframe, which must be unbolted to reach the mounting's fasteners (**see illustration**).

17 Unbolt the mounting from the subframe, then unscrew the mounting's centre bolt. If required, unbolt the mounting's bracket from

the transmission (**see illustrations**).

18 On refitting, ensure that the mounting-to-transmission bolts are securely tightened, then refit the mounting. Tighten first the mounting-to-subframe bolts, noting that these are to be tightened in two stages to the final specified torque wrench setting. Finally tighten the mounting's centre bolt, again to the specified torque wrench setting.